



# P1/PD Series: B-Mod Service Information Medium Pressure Axial Piston Pumps

Bulletin HY28-2708-02/SVC/EN

Effective: May 2024 Replaces: December 2020



ENGINEERING YOUR SUCCESS.

**Contents**

# Contents

Pump Identification & General Control Information..... 3  
 B-Mod vs A-mod Controls - C, L, & AM Controls..... 4  
 General Information..... 5  
 Typical Characteristics ..... 6

**Parts Data**

018, 028 B-mod Pump Exploded View ..... 7  
 045 B-mod Pump Exploded View ..... 8  
 018, 028, 045 B-mod Pump Parts ..... 9  
 060, 075, 085, 100, 140 B-mod Pump Exploded View ..... 10  
 060, 075, 085, 100, 140 B-mod Pump Parts ..... 11  
 Volume Stop Control ..... 12  
 Thru Drive Couplings and O-rings..... 13  
 C0 B-mod Control ..... 14  
 L0 B-mod Control..... 15  
 L2 B-mod Control..... 16  
 AM B-mod Control ..... 17  
 C, L, & AM Conversion Guide ..... 18  
 AN B-mod Control..... 29  
 L0T & AMT B-mod Controls ..... 30  
 ANT B-mod Control..... 32  
 C03/6 & L03/6 B-mod Electronic Unload Controls ..... 34  
 AE/AF B-mod Controls..... 36  
 AG/AH B-mod Controls..... 37  
 P, S, T, & U B-mod Electronic Controls ..... 38  
 Parts Kits ..... 40

**Assembly/Disassembly information**

Compensator Procedures ..... 41  
 Pump Service Procedures..... 43  
 Pump Inspection Procedures..... 45  
 Component Rework Limits..... 46  
 018, 028, 045 Assembly Procedures ..... 47  
 060, 075, 085, 100, 140 Assembly Procedures ..... 51  
 Assembly Tools ..... 55  
 Rotation Change ..... 59  
 Test Procedure ..... 61  
 Test Criteria & Start-up Procedures..... 63  
 Troubleshooting..... 64  
 Conversions and Formulas ..... 66  
 Content Changes & Warning..... 67



This service manual is to be used for P1/PD Design Series B (B-mod) pumps. In order to identify which series of pump you have, please refer to the Series Designation spot in the P1/PD model code as shown below.

For service information on A-mod pumps please refer to Bulletin HY28-2665-02/SVC/EN. The latest edition can be found at [www.parker.com/HPS](http://www.parker.com/HPS).

**B-Mod Design Series Designation**



**A-mod Design Series Designation**

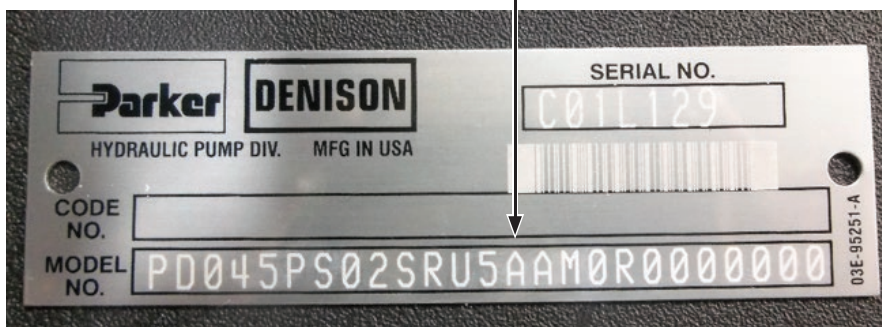

**General Control Information - B-mod vs A-mod**

The B-mod versions of the C, L, AM, AN, AE, & AF controls use a unique 5 port pattern on the control mounting pad in order to use the same control on clockwise and counterclockwise pumps. The A-mod versions used a standard D03/NG6 mounting pattern. Due to the control pad differences, these A-mod and B-mod controls are NOT directly interchangeable and require an adapter block in order to be used on the other design series pumps. Refer to the following page for details on the C, L, & AM control differences, and refer to the Parts Kits page for adapter block part numbers.

The AN, AE, & AF controls use the AM control plus an adapter block to allow for additional mounting of a D03/NG6 valve. See the respective Controls Sections for details.

The P, S, T, U, AG, & AH B-mod controls still use the same D03 pattern that was used on the A-mod. The P, S, T, & U B-mod controls use the D1FB valve instead of the D1FW valve that was used on the A-mod; however, both the D1FB and D1FW valves have the same D03 mounting pattern, so the D1FB valve can be used on an A-mod pump and vice versa.

The B-mod version of the AG & AH control actually uses the exact same controller as the A-mod. The only differences are internal to the housing and port block, so the AG & AH A-mod and B-mod controls are also interchangeable.

**Design Series A** **Design Series B**

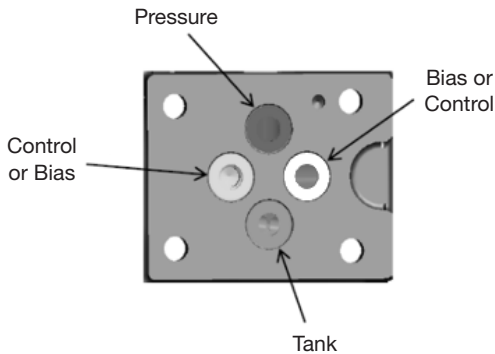
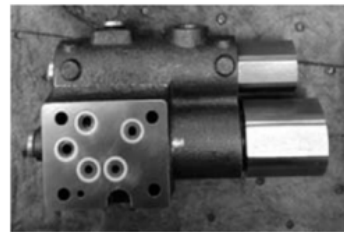
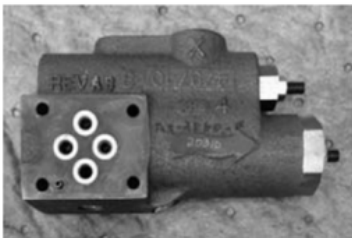
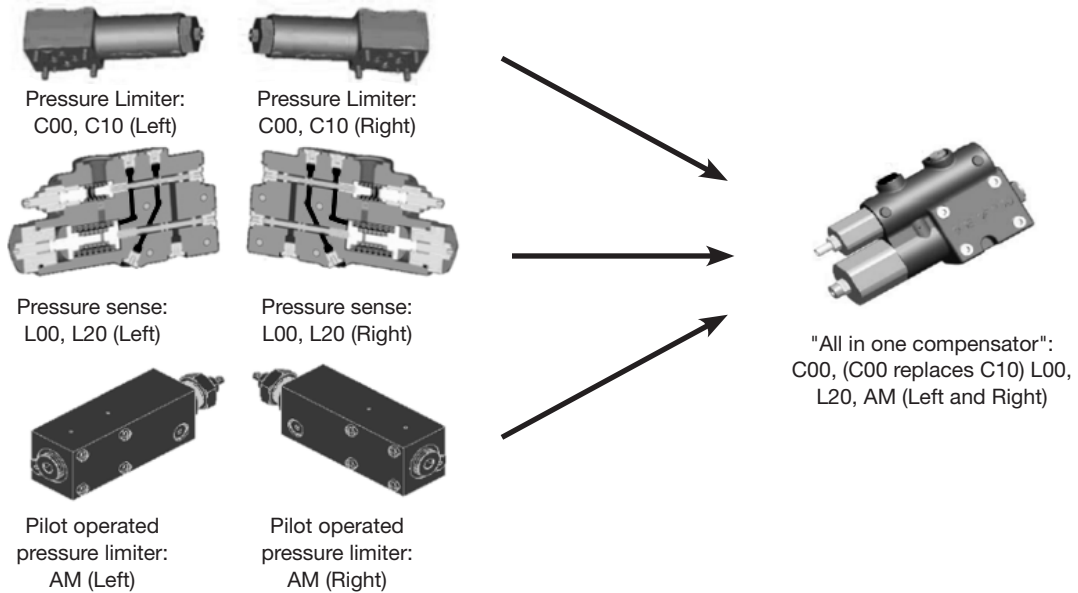

**Standard NG6/D03 Pattern**

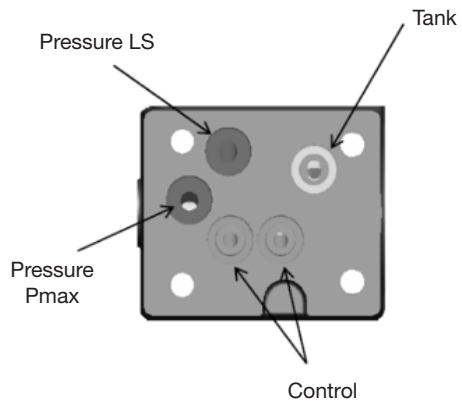

**Custom Control Pad Pattern**



<b>Model Coding Information</b>	For model code designation meaning and general model code information please see P1/PD sales catalog HY28-2665-01/P1/EN.
<b>Mounting</b>	<p>These pumps are designed to operate with the shaft horizontal or pointing downward. For shaft up, contact factory. The pump shaft must be in alignment with the shaft of the source driver and should be checked with a dial indicator. The mating pilot bore and coupling must be concentric. This concentricity is particularly important if the shaft is rigidly connected to the driven load without a flexible coupling.</p> <p><b>Splined:</b> The shafts will accept a maximum misalignment of 0.005 in (0.15mm) total indicator reading. Angular misalignment at the external and internal spline axis must be less than <math>\pm 0,002</math> mm per mm of shaft radius, <math>\pm 0.002</math> inches per inch of shaft radius. The coupling interface must be lubricated. PARKER recommends lithium molydisulfide or similar grease. The internal coupling should be hardened to Rc 27-34 and must conform to SAE-J498c, class 5 flat root side fit.</p> <p><b>Keyed:</b> High strength heat treated keys must be used. Replacement keys must be hardened to 27-34 Rc. The key corners must be chamfered 0.032-0.040 in (0.81-1.0 mm) at 45° to clear radii that exist in the keyway.</p>
<b>Side Load Capability</b>	The P1/PD series is designed for inline-drive. Side loading on the shaft is not recommended. If this is unavoidable consult your nearest Parker representative.
<b>Fluid Connections</b>	<p>Connect inlet and outlet lines to the port block of the pump. The maximum case pressure is 2 bar (30 psi) continuous, 4 bar (60 psi) intermittent. The case pressure must never exceed inlet pressure by more than .5 bar (7 psi). When connecting case drain line make certain that drain plumbing passes above highest point of the pump before passing to the reservoir. The case leakage line must be of sufficient size to prevent back pressure in excess of 2 bar (30 psi) and returned to the reservoir below the surface of the oil as far from the supply inlet as possible. All fluid lines, whether pipe, tubing, or hose must be adequate size and strength to assure free flow through the pump. An undersize inlet line will prevent the pump from operating properly at full rated speed. An undersize outlet line will cause back pressure and cause heat generation and increased noise. Flexible hose lines are recommended. If rigid piping is used, the workmanship must be accurate to eliminate strain on the pump port block or to the fluid connections. Sharp bends in the lines must be eliminated wherever possible. All system piping must be cleaned and flushed before installing pump. Make sure the entire hydraulic system is free of dirt, lint, scale, or other foreign material.</p> <p><b>CAUTION:</b> Do not use galvanized pipe. Galvanized coating can flake off with continued use.</p>
<b>System Relief Valves</b>	Although the P1/PD series pumps have very fast off-stroke compensator response, system relief valves are recommended in all cases for safety considerations.
<b>Recommended Fluids</b>	The fluid recommended for use in these pumps has a petroleum base and contains agents which provide oxidation inhibition and anti-rust, anti-foam and de-aerating properties as described in Parker standard HF-1. Where anti-wear additive fluids are specified, see Parker standard HF-0.
<b>Viscosity Index</b>	90 V. I. minimum. Higher values extend the range of operating temperature but may reduce the service life of the fluid. Viscosity cannot be lower than 7 cSt.
<b>Temperature</b>	Determined by the viscosity characteristics of the fluid used. Because high temperatures degrade seals, reduce the service life of the fluid and create hazards, fluid temperature should not exceed 230°F (110°C) at the case drain.
<b>Maintenance</b>	The pump is self-lubricating and preventative maintenance is limited to keeping system fluid clean by changing filters frequently. Keep all fittings and screws tight. Do not operate at pressures and speeds in excess of the recommended limit. If the pump does not operate properly, check the troubleshooting chart before attempting to overhaul the unit. Overhauling may be accomplished by referring to the disassembly, rework limits of wear parts, and assembly procedures as provided in this service manual.
<b>Fluid Cleanliness</b>	Fluid must be cleaned before and continuously during operation, by filters that maintain a cleanliness level of ISO 20/18/14. Better cleanliness levels will significantly extend the life of the components. As contaminant generation may vary with each application, each must be analyzed to determine proper filtration to maintain the required cleanliness level.

## Technical Data

Model	P1/PD 018	P1/PD 028	P1/PD 045	P1/PD 060	P1/PD 075	P1/PD 085	P1/PD 100	P1/PD 140
Maximum Displacement, cm <sup>3</sup> /rev cu.in./rev	18 1.10	28 1.71	45 2.75	60 3.66	75 4.58	85 5.19	100 6.01	140 8.54
Outlet Pressure – Continuous	280 bar (4060 psi)					250 bar (3600 psi)	280 bar (4060 psi)	
Intermittent*	320 bar (4640 psi)					300 bar (4350 psi)	320 bar (4640 psi)	
Peak	350 bar (5075 psi)					320 bar (4600 psi)	350 bar (5075 psi)	
P1 Maximum Speed (1.3 bar abs inlet), rpm	3500	3400	3100	2800	2700	2700	2500	2400
P1 (1.0 bar abs inlet), rpm	3300	3200	2800	2500	2400	2400	2250	2100
P1 (0.8 bar abs inlet), rpm	2900	2900	2400	2200	2100	2100	1900	1800
PD Maximum Speed (1.0 bar abs inlet), rpm	1800							
PD (0.8 bar abs inlet), rpm	1800							
Minimum Speed, rpm	600							
Inlet Pressure – Maximum	11 bar absolute (160 psi)							
Rated	1.0 bar absolute (14.5 psi)							
Minimum	0.8 bar absolute (11.6 psi)							
Case Pressure – Peak, bar	4.0 bar absolute (58 psi) and less than 0.5 bar (7.3 psi) above inlet pressure							
Rated, bar	2.0 bar absolute (29 psi) and less than 0.5 bar (7.3 psi) above inlet pressure							
Fluid Temperature Range, °C °F	-40 to +95 -40 to +203							
Fluid Viscosity – Rated, cSt	7 to 160							
Optimum Range, cSt	14-50 cSt.							
Max. Intermittent, cSt	5000 (for cold starting)							
Min. Intermittent, cSt	5							
Fluid Contamination – Rated, ISO	20/18/14							
Weight – End Port, kg (lb)	13.4 (29.5)	17.7 (39.0)	23 (50)	29 (64)	30 (66)	30 (66)	51 (112)	66 (145)
Side Port, kg (lb)	14.2 (31.3)	18.1 (40.0)	24 (52)	30 (67)	31 (68)	31 (68)	53 (117)	67 (147)
Thru-Drive, kg (lb)	15 (34)	22 (48)	27 (59)	34 (75)	35 (77)	35 (77)	55 (121)	82 (180)
Moment of Inertia kg-mm <sup>2</sup>	760	1555	3208	4548	5041	5041	12027	21400
Moment of Inertia Thru-Drive kg-mm <sup>2</sup>	793	1618	3268	4687	5207	5207	12402	22343

\*Intermittent pressure is defined as less than 10% of operation time, not exceeding 6 successive seconds.

## Typical Adjustment Ranges and Initial Settings for B-Mod Controls (Unless Customer Specified at Time of Order)

Function	Adjustment Range	Adjustment Value	Recommended or Initial Setting
Pressure compensator settings			
C, L, AM Controls	26-280 bar (380-4060 PSI)	55 bar/turn (800 PSI/turn)	70 bar (1000 psi)
Load sense differential settings			
"L0" and "L2"	10-40 bar (150-580 PSI)	16 bar/turn (230 PSI/turn)	20 bar (290 PSI)
Maximum volume stop			
018	100-40%	9% per turn (1.6 cc/turn)	100%
028	100-40%	8.2% per turn (2.3 cc/turn)	100%
045	100-20%	7.5% per turn (3.4 cc/turn)	100%
060	100-30%	6.8% per turn (4.1 cc/turn)	100%
075/085	100-35%	6.2% per turn (4.7/5.2 cc/turn)	100%
100	100-50%	5.5% per turn (5.5 cc/turn)	100%
140	100-50%	4.8% per turn (6.7 cc/turn)	100%
Minimum volume stop			
018	0-68%	10% per turn (1.8 cc/turn)	0%
028	0-40%	9% per turn (2.6 cc/turn)	0%
045	0-40%	8.2% per turn (3.7 cc/turn)	0%
060	0-50%	4.6% per turn (2.8 cc/turn)	0%
075/085	0-45%	4.3% per turn (3.2/3.7 cc/turn)	0%
100	0-45%	3.9% per turn (3.9 cc/turn)	0%
140	0-25%	3.3% per turn (4.6 cc/turn)	0%

\* Clockwise Rotation Shown

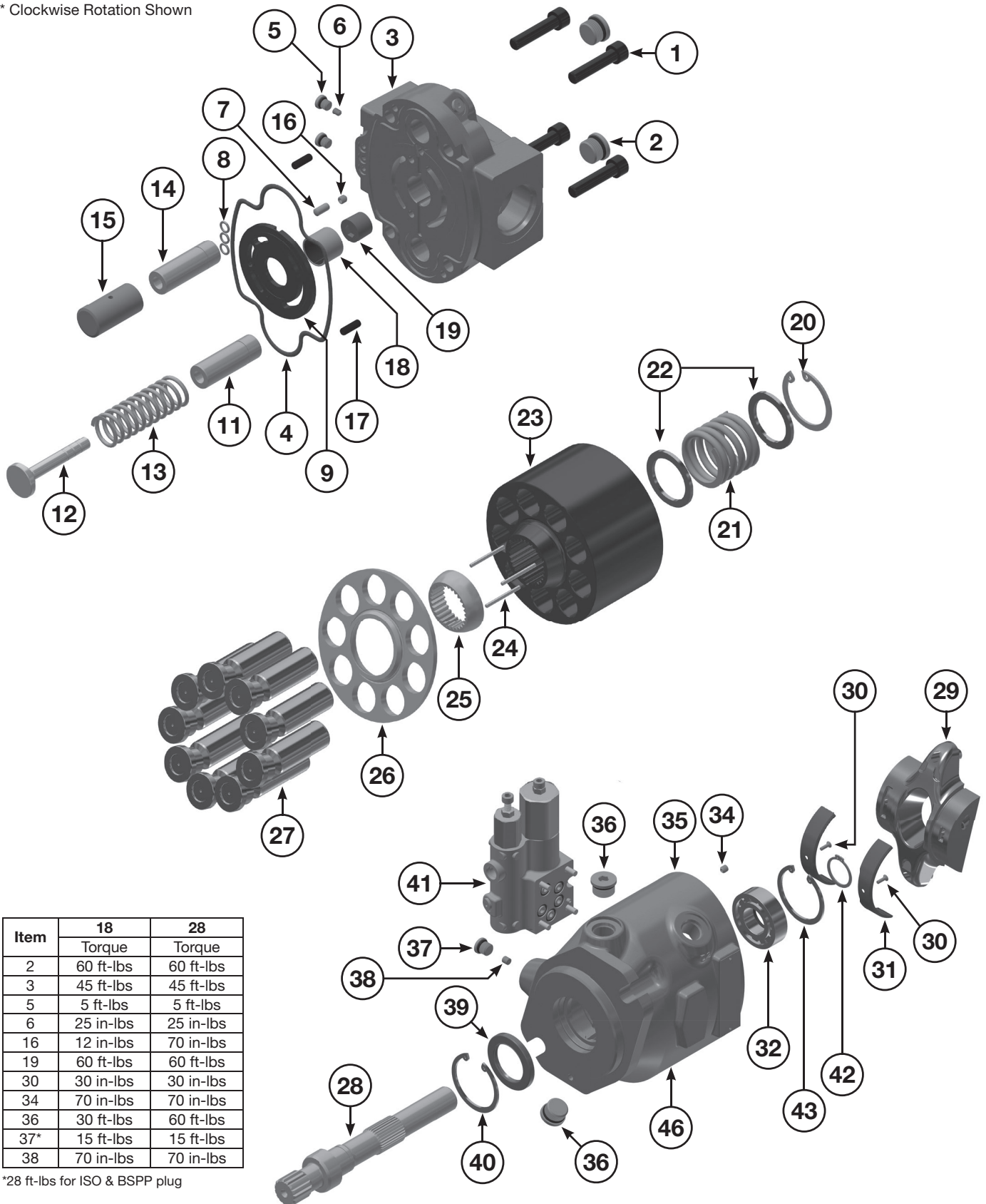

Item	18	28
	Torque	Torque
2	60 ft-lbs	60 ft-lbs
3	45 ft-lbs	45 ft-lbs
5	5 ft-lbs	5 ft-lbs
6	25 in-lbs	25 in-lbs
16	12 in-lbs	70 in-lbs
19	60 ft-lbs	60 ft-lbs
30	30 in-lbs	30 in-lbs
34	70 in-lbs	70 in-lbs
36	30 ft-lbs	60 ft-lbs
37*	15 ft-lbs	15 ft-lbs
38	70 in-lbs	70 in-lbs

\*28 ft-lbs for ISO & BSPP plug

**045 B-mod Pump Exploded View**

\* Clockwise Rotation Shown

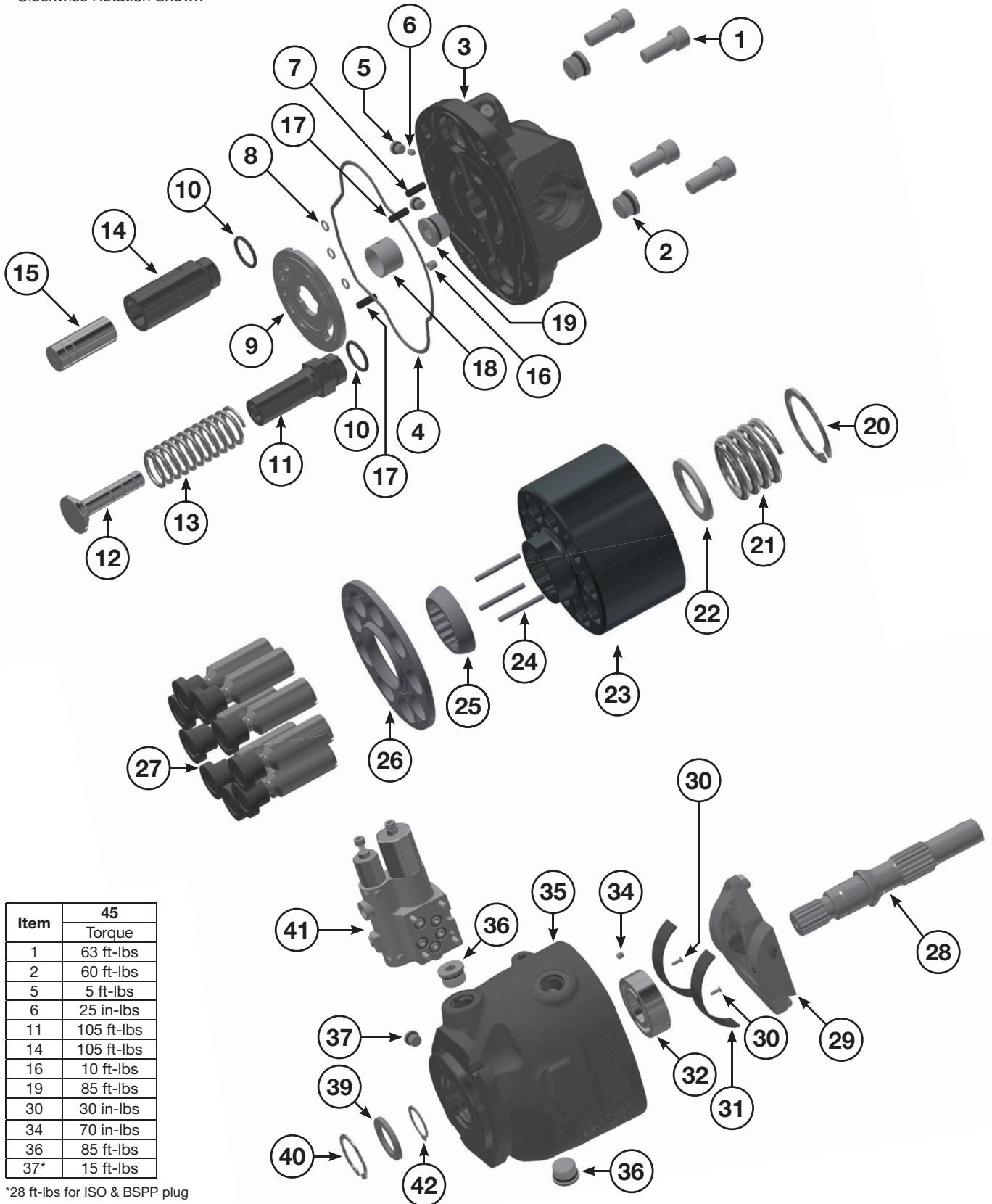

Item	45 Torque
1	63 ft-lbs
2	60 ft-lbs
5	5 ft-lbs
6	25 in-lbs
11	105 ft-lbs
14	105 ft-lbs
16	10 ft-lbs
19	85 ft-lbs
30	30 in-lbs
34	70 in-lbs
36	85 ft-lbs
37*	15 ft-lbs

\*28 ft-lbs for ISO & BSPP plug





**018, 028, 045 Pump Parts**

Item No	Qty	018 Part No	028 Part No	045 Part No	Description
1	4	210x209	210x211	361-12229-0	Socket head cap screws
	4	**	210x209	**	Socket head cap screws (28cc thru drive version only)
2*	2	108X8V	108X8V	108X8V	Volume stop boss plug & O-ring
3	1	Contact factory for port block ordering information.			Port block
4*	1	2050V-7	2160V-7	675-00162-0	Port block O-ring
5*	4	108X2V	108X2V	108X2V	Boss plug & O-ring
6	1	226X42	226X42	226X42	M5X6 Control Flow Set Screw
7	1	299X67	324-30014-0	324-30014-0	Port plate pin
8*	3	605-10077-0	605-10077-0	605-10077-0	Control pressure passage o-rings
9***	1	03E-94415-0	03E-94969-0	03E-94339-0	Port plate, CW, industrial (PD)
		03E-94414-0	03E-94970-0	03E-94340-0	Port plate, CCW, industrial (PD)
		03E-94413-0	03E-94969-0	03E-94341-0	Port plate, CW, mobile (P1)
		03E-94416-0	03E-94970-0	03E-94342-0	Port plate, CCW, mobile (P1)
		03E-94963-0	03E-94376-0	03E-95374-0	Port plate, CW, industrial (PD), ripple chamber
		03E-94964-0	03E-94377-0	03E-95375-0	Port plate, CCW, industrial (PD), ripple chamber
		03E-94965-0	03E-94378-0	03E-95374-0	Port plate, CW, mobile (P1), ripple chamber
03E-94966-0	03E-94379-0	03E-95375-0	Port plate, CCW, mobile (P1), ripple chamber		
10*	2	**	**	695-00912-0	Bias and control rod O-ring
11	1	03E-94427-0	03E-94390-0	03E-94355-0	Bias guide
	1	**	**	03E-95658-0	Bias guide (overcenter option)
12	1	03E-94428-0	03E-94391-0	03E-94354-0	Bias piston
13	1	03E-94430-0	03E-94393-0	03E-94356-0	Bias spring
	1	**	**	03E-95656-0	Bias spring (overcenter option)
14	1	03E-94427-0	03E-94390-0	03E-94353-0	Control guide
	1	**	**	03E-95657-0	Control guide (overcenter option)
15	1	03E-94426-0	03E-94389-0	03E-94352-0	Control piston
16	1	226X14	226X56	102x1	Ripple chamber plug (side ported version only)
17	2	299X123	299X123	299X123	Cover dowel pin
18	1	216-10013-0	789814	230-82227-0	Port block bushing
19	1	102X8	102X8	108X10V	Ripple chamber plug (side ported only)
20	1	256X521	256X525	356-65158-0	Retaining ring, internal
21	1	787635	03E-94387-0	03E-94350-0	Barrel hold down spring
22	2 (1:045)	786996	03E-94388-0	03E-94351-0	Barrel hold down washer
23	1	03E-94717-0	03E-94375-0	03E-94338-0	Barrel
24	3	787000	03E-97011-0	03E-95903-0	Barrel hold down pin
25	1	787002	03E-94385-0	03E-96852-0	Spherical washer
26	1	786994	03E-94384-0	03E-96988-0	Retainer plate
27	9	789641	S2E-18415-0	S2E-18413-0	Piston and shoe assembly
28	1	03E-94409-0	03E-94372-0	03E-94335-0	01 shaft option, no thru drive
		03E-94411-0	03E-94374-0	03E-94337-0	01 shaft option with thru drive
		S2E-19657-0	S2E-19661-0	S2E-19665-0	02 shaft option assembly with key (no thru drive)
		S2E-19658-0	S2E-19662-0	S2E-19666-0	02 shaft option assembly (thru drive)
		S2E-19659-0	S2E-19663-0	S2E-19667-0	04 shaft option assembly with key (no thru drive)
		S2E-19660-0	S2E-19664-0	S2E-19668-0	04 shaft option assembly (thru drive)
		03E-94718-0	**	**	06 shaft option assembly (no thru drive)
		03E-96233-0	**	**	06 shaft option assembly (thru drive)
03E-94804-0	03E-95166-0	03E-94990-0	08 shaft option, (no thru drive)		
03E-94762-0	03E-95492-0	03E-95197-0	08 shaft option (thru drive)		
29	1	S2E-19079-0	S2E-18414-0	S2E-18412-0	Cam
30	2	03E-94359-0	03E-94359-0	03E-94359-0	Bearing retainer screws
31	2	03E-94432-0	03E-94395-0	03E-94358-0	Cam bearing
32	1	230-82515-0	789815	230-82516-0	Cylindrical roller bearing
34	1	226X56	226X56	226X56	M6X6 bias flow set screw
35	1	**	**	**	Housing (not sold separately)
36*	2	108X6V	108X8V	108X10V	Case drain plug & O-ring - SAE ORB
		788153V	788161V	788161V	Case drain plug & O-ring - BSPP
		788516-06V	788516-10V	788516-10V	Case drain plug & O-ring - ISO
37*	1	108X4V	108X4V	108X4V	BG port plug & O-ring - SAE ORB
		789189V	789189V	789189V	BG port plug & O-ring - BSPP
		788516-04V	788516-04V	788516-04V	BG port plug & O-ring - ISO
38*	1	P2-000-3506-08	P2-000-3506-08	**	M6X6 set screw with 0.8mm orifice
39*	1	787140	P2-060-3304	03E-96890-0	Shaft seal
40	1	256X535	256X544	356-65144-0	Seal retainer
41	1	See separate compensator ordering information			Compensator
42	1	256X222	256X222	356-65159-0	External retaining ring (shaft)
43	1	256X544	256X544	**	Internal retaining ring (housing)

\* Denotes seal or O-ring is included in the seal kit | \*\*\* Contact factory for 045 overcenter "X" port plate part number information



\* Counter-clockwise Rotation Shown

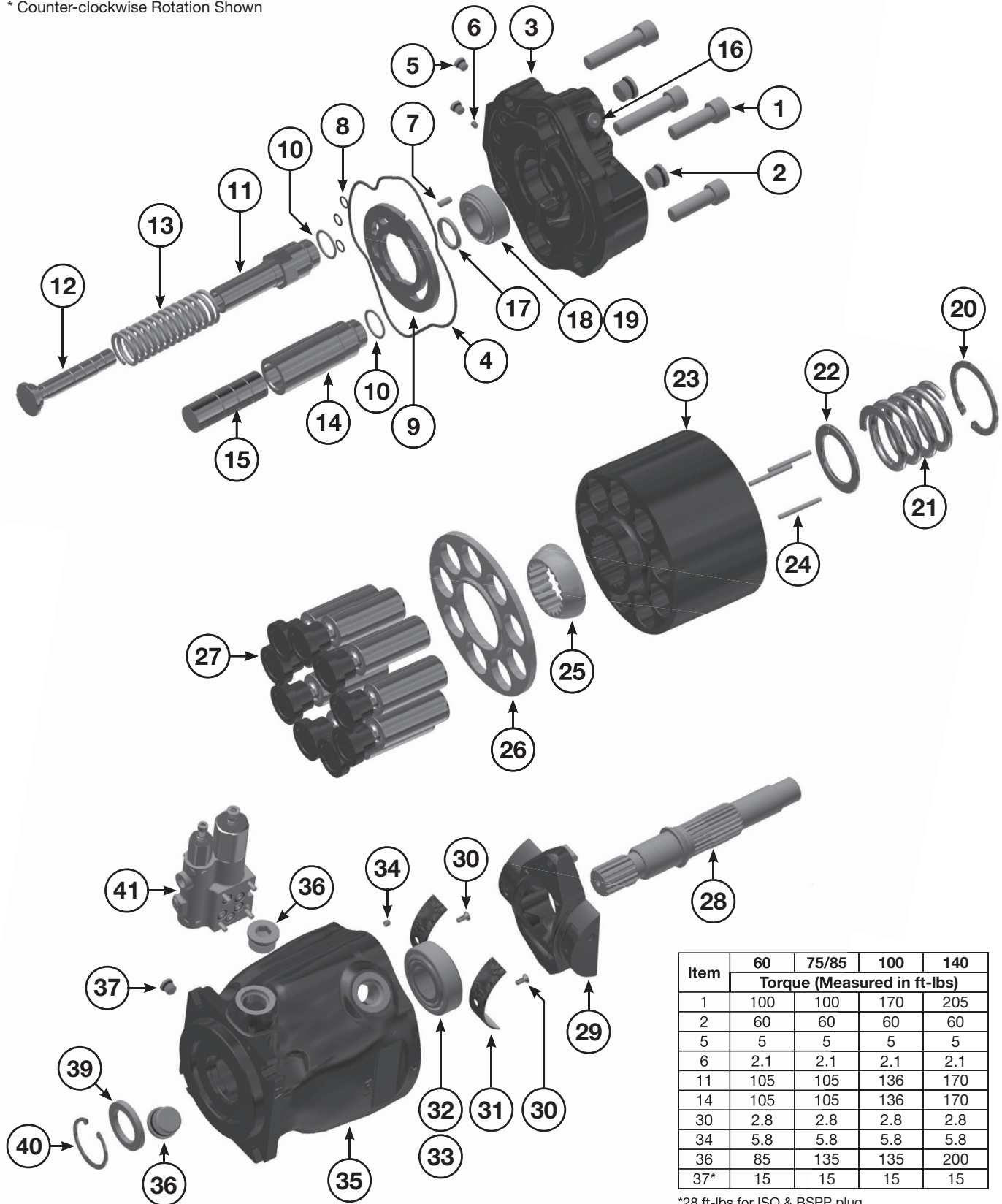

Item	60	75/85	100	140
	Torque (Measured in ft-lbs)			
1	100	100	170	205
2	60	60	60	60
5	5	5	5	5
6	2.1	2.1	2.1	2.1
11	105	105	136	170
14	105	105	136	170
30	2.8	2.8	2.8	2.8
34	5.8	5.8	5.8	5.8
36	85	135	135	200
37*	15	15	15	15

\*28 ft-lbs for ISO & BSPP plug



Item No	Qty	060 Part No	075 Part No	085 Part No	100 Part No	140 Part No	Description
1	4 (2: 075/085)	361-13250-0	361-13270-0	361-13270-0	361-14290-0	361-15270-0	Socket head cap screws (non-thru drive version)
	0 (2: 075/085)	361-13250-0	361-13250-0	361-13250-0	361-14290-0	361-15270-0	
	4	361-13250-0	361-13250-0	361-13250-0	361-14290-0	361-15267-0	Socket head cap screws (thru drive version only)
2*	2	108X8V	108X8V	108X8V	108X8V	108X8V	Volume stop boss plug & O-ring
3	1	Contact factory for port block ordering information.					Port block
4*	1	675-00164-0	675-00165-0	675-00165-0	675-00170-0	675-00173-0	Port block O-ring
5*	2	108X2V	108X2V	108X2V	108X2V	108X2V	Boss plug & O-ring
6	1	226X42	226X42	226X42	226X42	226X42	M5X6 control flow set screw
7	1	324-30014-0	324-30014-0	324-30014-0	324-30014-0	324-30014-0	Port plate pin
8*	3	605-10070-0	605-10070-0	605-10070-0	605-10070-0	605-10070-0	Control pressure O-rings
9***	1	03E-94038-0	03E-93169-0	03E-93169-0	03E-95605-0	03E-93252-0	Port plate, CW, industrial (PD)
		03E-94039-0	03E-93170-0	03E-93170-0	03E-95606-0	03E-93253-0	Port plate, CCW, industrial (PD)
		03E-94040-0	03E-93171-0	03E-93171-0	03E-95607-0	03E-93254-0	Port plate, CW, mobile (P1)
		03E-94041-0	03E-93172-0	03E-93172-0	03E-95608-0	03E-93255-0	Port plate, CCW, mobile (P1)
10*	2	695-00912-0	695-00912-0	695-00912-0	695-00914-0	695-00916-0	Bias and control rod O-ring
11	1	03E-94054-0	03E-93150-0	03E-93150-0	03E-93800-0	03E-93248-0	Bias guide
		03E-94832-0	03E-94498-0	**	03E-94827-0	03E-94743-0	Bias guide (overcenter option "X")
12	1	03E-94053-0	03E-93149-0	03E-93149-0	03E-93799-0	03E-94658-0	Bias piston
		03E-94835-0	03E-93149-0	**	03E-93799-0	03E-94658-0	Bias piston (overcenter option "X")
13	1	03E-94055-0	03E-93151-0	03E-93151-0	03E-93801-0	03E-93963-0	Bias spring
		03E-94834-0	03E-94499-0	**	03E-94829-0	03E-94752-0	Bias spring (overcenter option "X")
14	1	03E-94052-0	03E-93148-0	03E-95471-0	03E-93798-0	03E-97335-0	Control guide
		03E-94833-0	03E-94608-0	**	03E-94828-0	03E-93246-0	Control guide (overcenter option "X")
15	1	03E-94051-0	03E-93147-0	03E-93147-0	03E-93797-0	03E-94751-0	Control piston
16*	2	108X4V	108X4V	108X4V	108X4V	108X4V	Boss plug & O-ring
17	1	S2E-18591-0K	S2E-18591-0K	S2E-18591-0K	S2E-18640-0K	S2E-18527-0K	Bearing shim kit (includes all standard shim sizes)
18	1	230-82237-0	230-82237-0	230-82237-0	230-82244-0	230-82239-0	Tapered roller bearing cup
19	1	INCLUDED IN ITEM 18			230-82518-0	INCLUDED IN ITEM 18	
20	1	356-65152-0	356-65144-0	356-65144-0	356-65146-0	356-65147-0	Retaining ring, internal
21	1	03E-94049-0	03E-93145-0	03E-93145-0	03E-93795-0	03E-94672-0	Barrel hold down spring
22	1	03E-94050-0	03E-93146-0	03E-93146-0	03E-93796-0	03E-93244-0	Barrel hold down washer
23	1	03E-94036-0	03E-93129-0	03E-95465-0	03E-95603-0	03E-93242-0	Barrel
		03E-94036-0	03E-93129-0	03E-95465-0	03E-95603-0	03E-95641-0	Barrel (overcenter option "X")
24	3	03E-95904-0	03E-95905-0	03E-95905-0	03E-95906-0	03E-95907-0	Barrel hold down pin
25	1	03E-94047-0	03E-93142-0	03E-93142-0	03E-93794-0	03E-93241-0	Spherical washer
26	1	03E-97012-0	03E-97013-0	03E-97003-0	03E-97014-0	03E-97009-0	Retainer plate
27	9	S2E-18296-0	S2E-17003-0	S2E-19330-0	S2E-17912-0	S2E-17323-0	Piston and shoe assembly
28	1	03E-94032-0	03E-93999-0	03E-93999-0	03E-93779-0	03E-93227-0	01 shaft option, no thru drive
		03E-94033-0	03E-94000-0	03E-94000-0	03E-93780-0	03E-93228-0	01 shaft option with thru drive
		S2E-19669-0	S2E-19673-0	S2E-19673-0	S2E-19677-0	S2E-19681-0	02 shaft option assembly with key (no thru drive)
		S2E-19670-0	S2E-19674-0	S2E-19674-0	S2E-19678-0	S2E-19682-0	02 shaft option assembly (thru drive)
		S2E-19671-0	S2E-19675-0	S2E-19675-0	S2E-19679-0	S2E-19683-0	04 shaft option assembly with key (no thru drive)
		S2E-19672-0	S2E-19676-0	S2E-19676-0	S2E-19680-0	S2E-19684-0	04 shaft option assembly (thru drive)
		03E-95611-0	**	**	03E-94500-0	**	06 (100cc) & 09 (60cc) shaft options, no thru drive
		03E-96177-0	**	**	03E-94462-0	**	06 (100cc) & 09 (60cc) shaft options, thru drive
03E-96216-0	**	**	**	**	10 shaft option, no thru drive		
29	1	S2E-18411-0	S2E-17443-0	S2E-17443-0	S2E-17961-0	S2E-17957-0	Cam
30	2	03E-93763-0	03E-93763-0	03E-93763-0	03E-93763-0	03E-93763-0	Bearing retainer screws
31	2	03E-94057-0	03E-93950-0	03E-93950-0	03E-93952-0	03E-93953-0	Cam bearing
32	1	230-82236-0	230-82236-0	230-82236-0	230-82519-0	230-82241-0	Tapered roller bearing cone (and cup 140)
33	1	230-82235-0	230-82235-0	230-82235-0	230-82245-0	**	Tapered roller bearing cup
34	1	226X56	226X56	226X56	226X56	226X56	M6X6 bias flow set screw
35	1	**	**	**	**	**	Housing (not sold separately)
36*	2	108X10V	108X12V	108X12V	108X12V	108X16V	Case drain plug & O-ring - SAE ORB
		788175V	788175V	788175V	788175V	447-00038-5	Case drain plug & O-ring - BSPP
		788516-10V	788516-12V	788516-12V	788516-12V	788516-16V	Case drain plug & O-ring - ISO
37*	1	108X4V	108X4V	108X4V	108X4V	108X4V	BG port plug & O-ring - SAE ORB
		789189V	789189V	789189V	789189V	789189V	BG port plug & O-ring - BSPP
		788516-04V	788516-04V	788516-04V	788516-04V	788516-04V	BG port plug & O-ring - ISO
39*	1	620-82118-5	620-82118-5	620-82118-5	620-82121-5	620-82120-5	Shaft seal
40	1	356-65146-0	356-65146-0	356-65146-0	356-65147-0	356-65148-0	Seal retainer
41	1	See separate compensator ordering information.					Compensator

\* Denotes seal or O-ring is included in the seal kit | \*\*\* Contact factory for overcenter "X" port plate part number information



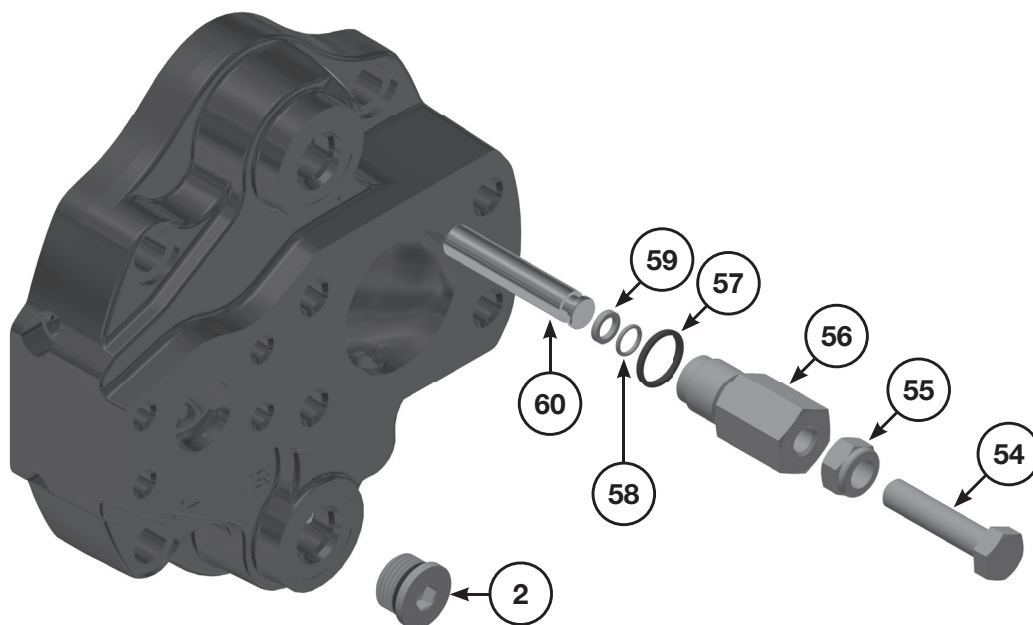

**NOTE:** Picture shows max volume stop location for counter-clockwise rotation and min volume stop location for clockwise rotation. Plug and stop assembly locations would be switched for opposite rotation.

Volume Stop Parts		
Item No	Qty	Description
2	1	Plug with O-ring (no volume stop)
54	1	Adjusting screw
55	1	Adjusting screw lock nut
56	1	Volume stop plug
57	1	Volume stop plug O-ring
58	1	Backup ring
59	1	Volume stop rod O-ring
60*	1	Volume stop rod

Item	Torque
2	60 ft-lbs
55	18 ft-lbs
56	45 ft-lbs

\*Min & max rods same for the 45 thru 140, but different on the 18 & 28. See table below for kit part number.

Volume Stop Kits							
Size	018	028	045	060	075/085	100	140
Maximum volume stop kit	S2E-19203-5K	S2E-19204-5K	S2E-19115-5K				
Minimum volume stop kit	S2E-19608-5K	S2E-19609-5K	S2E-19115-5K				



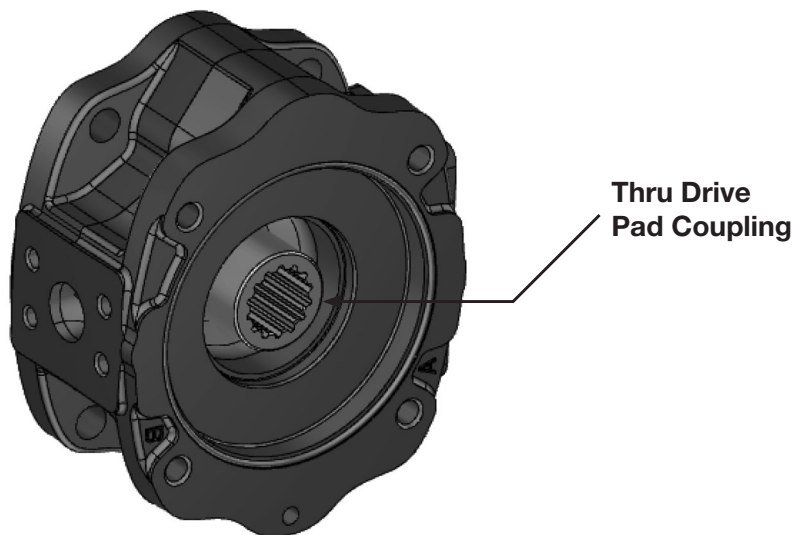

Thru Drive Pad Coupling	Thru Drive Couplings							O-ring
	018	028	045	060	075/085	100	140	
SAE A, 9 Tooth	S2E-19538-0	S2E-19364-0	03E-94942-0	03E-93278-0	03E-93278-0	03E-94274-0	03E-93947-0	695-00237-0
SAE A, 11 Tooth	S2E-19726-0	S2E-19391-0	03E-94943-0	03E-94724-0	03E-94724-0	03E-94657-0	03E-95706-0	695-00237-0
SAE B, 13 Tooth	**	S2E-19365-0	03E-94945-0	03E-93277-0	03E-93277-0	03E-94273-0	03E-93946-0	695-00243-0
SAE BB, 15 Tooth	**	S2E-19409-0	03E-94361-0	03E-93279-0	03E-93279-0	03E-94272-0	03E-93945-0	695-00243-0
SAE C, 14 Tooth	**	**	**	03E-93276-0	03E-93276-0	03E-94271-0	03E-93944-0	695-00251-0
SAE CC, 17 Tooth	**	**	**	**	**	03E-94270-0	03E-93943-0	695-00251-0
SAE D&E, 13 Tooth	**	**	**	**	**	**	03E-93942-0	695-00259-0

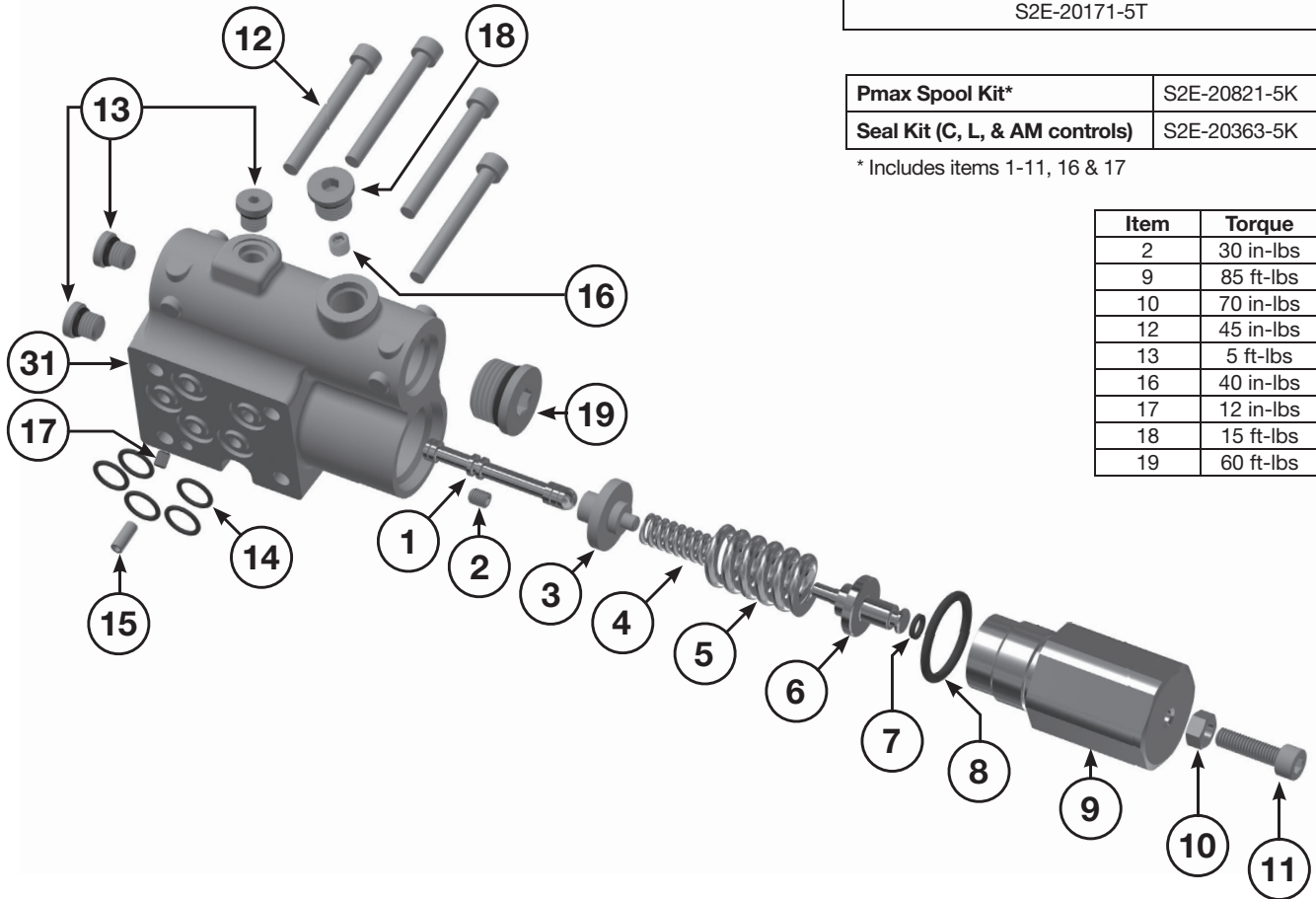

C0 Controller Assembly Part Number	
S2E-20171-5T	

Pmax Spool Kit*	S2E-20821-5K
Seal Kit (C, L, & AM controls)	S2E-20363-5K

\* Includes items 1-11, 16 & 17

Item	Torque
2	30 in-lbs
9	85 ft-lbs
10	70 in-lbs
12	45 in-lbs
13	5 ft-lbs
16	40 in-lbs
17	12 in-lbs
18	15 ft-lbs
19	60 ft-lbs

Item	Qty	Part Number	Description
1	1	03E-95926-0	Pmax spool
2	1	226X42	M5 x 6 set screw
3	1	Available in kit only	Pmax inner spring guide
4	1	Available in kit only	Pmax inner spring
5	1	Available in kit only	Pmax outer spring
6	1	Available in kit only	Pmax outer spring guide
7*	1	Available in kit only	Pmax outer spring guide O-ring
8*	1	Available in kit only	Pmax main O-ring
9	1	03E-95570-0	Pmax outer cap
10	1	340-00063-0	Pmax adjustment lock nut
11	1	361-08275-0	Pmax M6x22 adjustment screw
12	4	361-07253-8	M5 x 45 SHCS
13*	3	108X2V	SAE Boss Plug & O-ring
14*	5	Available in kit only	Compensator teflon O-ring
15	1	325-36001-0	Compensator M4 x 10 roll pin
16	1	226X56	M6 x 6 set screw
17	1	226X26	M4 x 5 set screw
18	1	108X4V	Boss plug & O-ring - SAE
19	1	108X8V	Boss plug & O-ring
31	1	Not sold separately	Compensator housing

\*Included in C, L, & AM controls seal kit

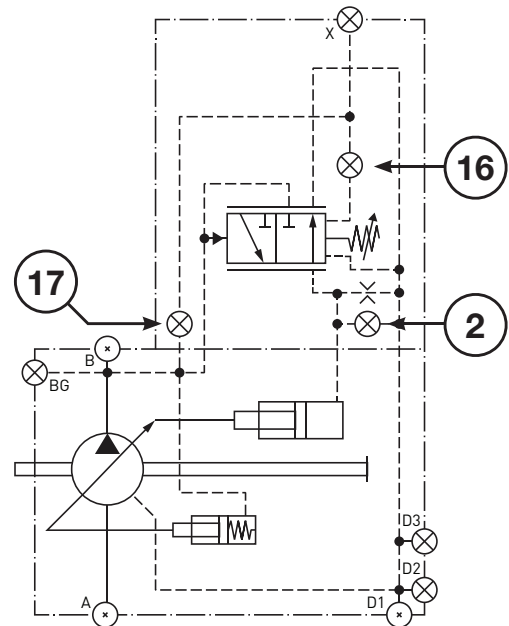

Item	Torque
2	30 in-lbs
9	85 ft-lbs
10	70 in-lbs
12	45 in-lbs
13	5 ft-lbs
16	40 in-lbs
28	50 ft-lbs
29	70 in-lbs

L0 Controller Assembly Part Numbers	
SAE*	S2E-19440-5T
Metric*	S2E-20186-5T
BSP**	S2E-20189-5T

\* Designates load sense port thread type

Pmax Spool Kit**	S2E-20821-5K
Load Sense Spool Kit***	S2E-20822-5K
Seal Kit (C, L, & AM controls)	S2E-20363-5K

\*\* Includes items 1-11, 16 & 17

\*\*\* Includes items 2, 16, 20-30

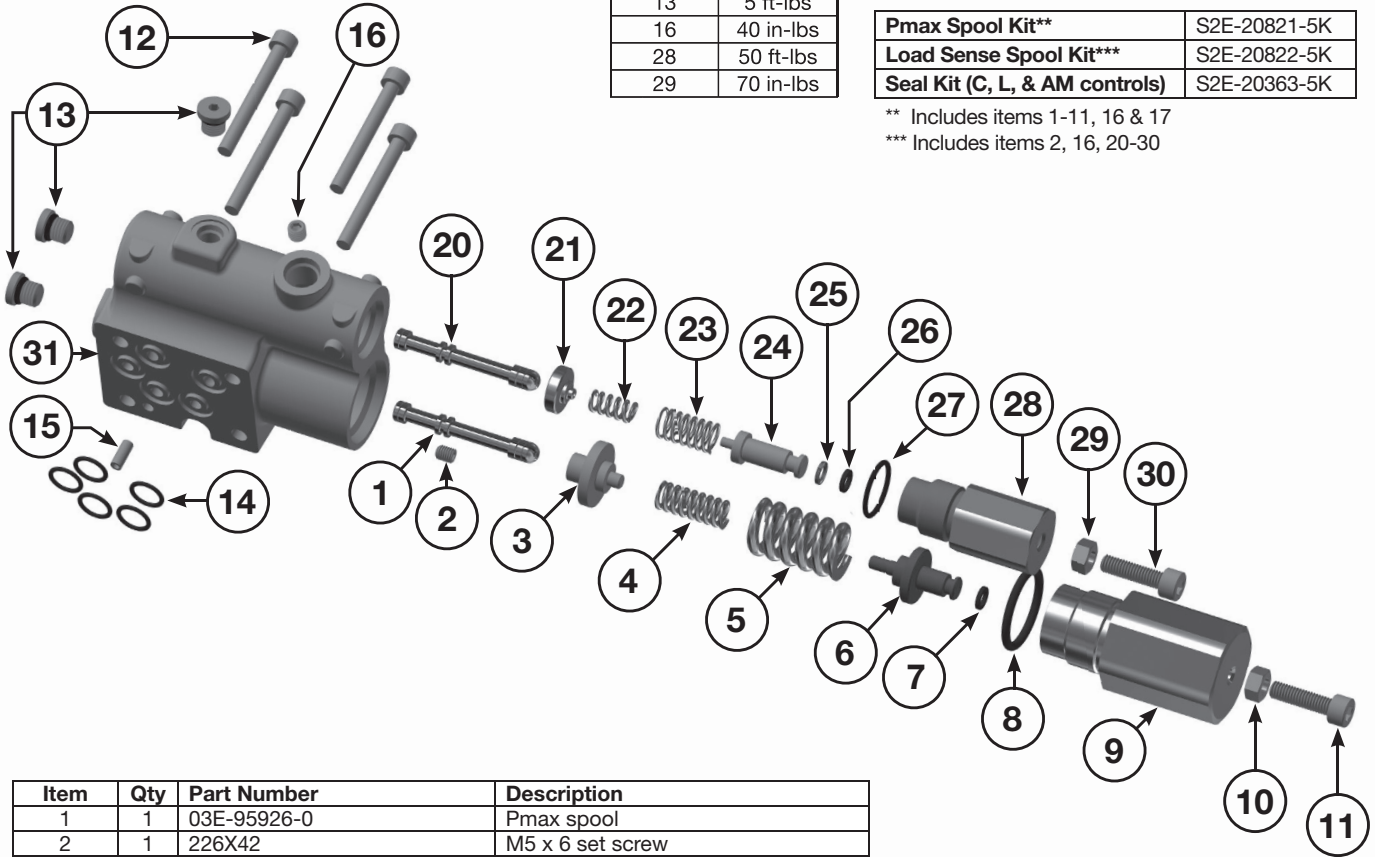

Item	Qty	Part Number	Description
1	1	03E-95926-0	Pmax spool
2	1	226X42	M5 x 6 set screw
3	1	Available in kit only	Pmax inner spring guide
4	1	Available in kit only	Pmax inner spring
5	1	Available in kit only	Pmax outer spring
6	1	Available in kit only	Pmax outer spring guide
7*	1	Available in kit only	Pmax outer spring guide O-ring
8*	1	Available in kit only	Pmax main O-ring
9	1	03E-95570-0	Pmax outer cap
10	1	340-00063-0	Pmax adjustment lock nut
11	1	361-08275-0	Pmax M6x22 adjustment screw
12	4	361-07253-8	M5 x 45 SHCS
13*	3	108X2V	SAE Boss Plug & O-ring
14*	5	Available in kit only	Compensator teflon O-ring
15	1	325-36001-0	Compensator M4 x 10 roll pin
16	1	226X56	M6 x 6 set screw
20	1	03E-95926-0	Differential spool
21	1	Available in kit only	Differential inner spring guide
22	1	Available in kit only	Differential inner spring
23	1	Available in kit only	Differential outer spring
24	1	Available in kit only	Differential outer spring guide
25*	1	Available in kit only	Differential inner spring guide O-ring
26*	1	Available in kit only	Differential inner spring guide O-ring
27*	1	Available in kit only	Differential main O-ring
28	1	03E-95572-0	Differential outer cap
29	1	340-00063-0	Differential adjustment lock nut
30	1	361-08275-0	Differential M6x22 adjustment screw
31	1	Not sold separately	Compensator housing

\*Included in C, L, & AM controls seal kit

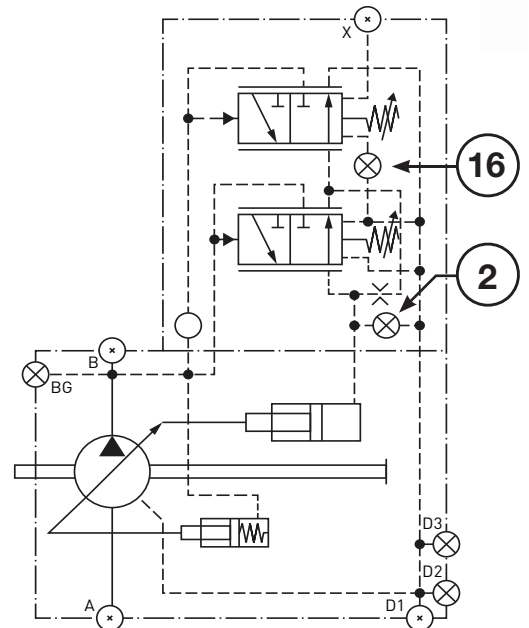

Item	Torque
2	30 in-lbs
9	85 ft-lbs
10	70 in-lbs
12	45 in-lbs
13	5 ft-lbs
16	40 in-lbs
28	50 ft-lbs
29	70 in-lbs

L2 Controller Assembly Part Numbers	
SAE*	S2E-20196-5T
Metric*	S2E-20187-5T
BSP*	S2E-20190-5T

\* Designates load sense port thread type

Pmax Spool Kit**	S2E-20821-5K
Load Sense Spool Kit***	S2E-20822-5K
Seal Kit (C, L, & AM controls)	S2E-20363-5K

\*\* Includes items 1-11, 16 & 17

\*\*\* Includes items 2, 16, 20-30

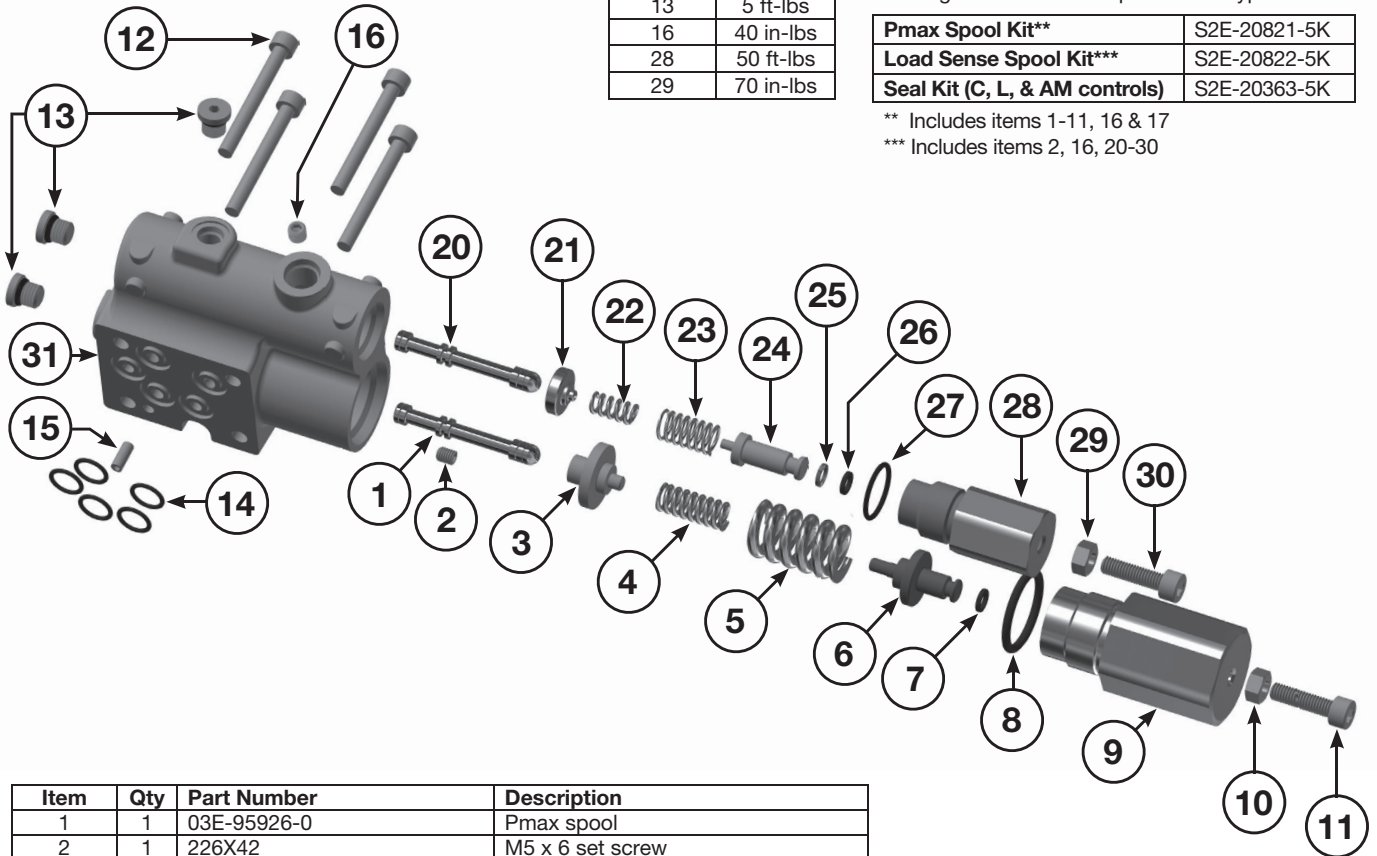

Item	Qty	Part Number	Description
1	1	03E-95926-0	Pmax spool
2	1	226X42	M5 x 6 set screw
3	1	Available in kit only	Pmax inner spring guide
4	1	Available in kit only	Pmax inner spring
5	1	Available in kit only	Pmax outer spring
6	1	Available in kit only	Pmax outer spring guide
7*	1	Available in kit only	Pmax outer spring guide O-ring
8*	1	Available in kit only	Pmax main O-ring
9	1	03E-95570-0	Pmax outer cap
10	1	340-00063-0	Pmax adjustment lock nut
11	1	361-08275-0	Pmax M6x22 adjustment screw
12	4	361-07253-8	M5 x 45 SHCS
13*	3	108X2V	SAE Boss Plug & O-ring
14*	5	Available in kit only	Compensator teflon O-ring
15	1	325-36001-0	Compensator M4 x 10 roll pin
16	1	P2-000-3506-04	M6 x 6 set screw with 0.4mm orifice
20	1	03E-95926-0	Differential spool
21	1	Available in kit only	Differential inner spring guide
22	1	Available in kit only	Differential inner spring
23	1	Available in kit only	Differential outer spring
24	1	Available in kit only	Differential outer spring guide
25*	1	Available in kit only	Differential inner spring guide O-ring
26*	1	Available in kit only	Differential inner spring guide O-ring
27*	1	Available in kit only	Differential main O-ring
28	1	03E-95572-0	Differential outer cap
29	1	340-00063-0	Differential adjustment lock nut
30	1	361-08275-0	Differential M6x22 adjustment screw
31	1	Not sold separately	Compensator housing

\*Included in C, L, & AM controls seal kit

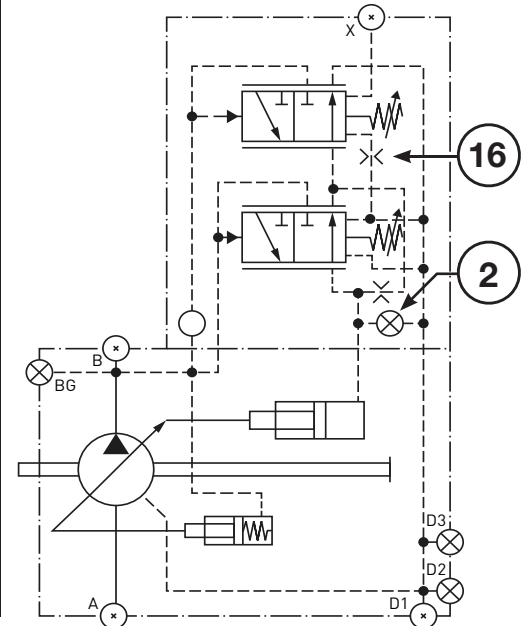



Item	Torque
2	30 in-lbs
9	85 ft-lbs
10	70 in-lbs
12	45 in-lbs
13	5 ft-lbs
16	40 in-lbs
28	50 ft-lbs
29	70 in-lbs

AM Controller Assembly Part Numbers	
SAE*	S2E-20172-5T
Metric*	S2E-20188-5T
BSP*	S2E-20191-5T

\* Designates remote port thread type

Pmax Spool Kit**	S2E-20821-5K
AM Spool Kit***	S2E-20823-5K
Seal Kit (C, L, & AM controls)	S2E-20363-5K

\*\* Includes items 1-11, 16 & 17

\*\*\* Includes items 2, 16, 20-30

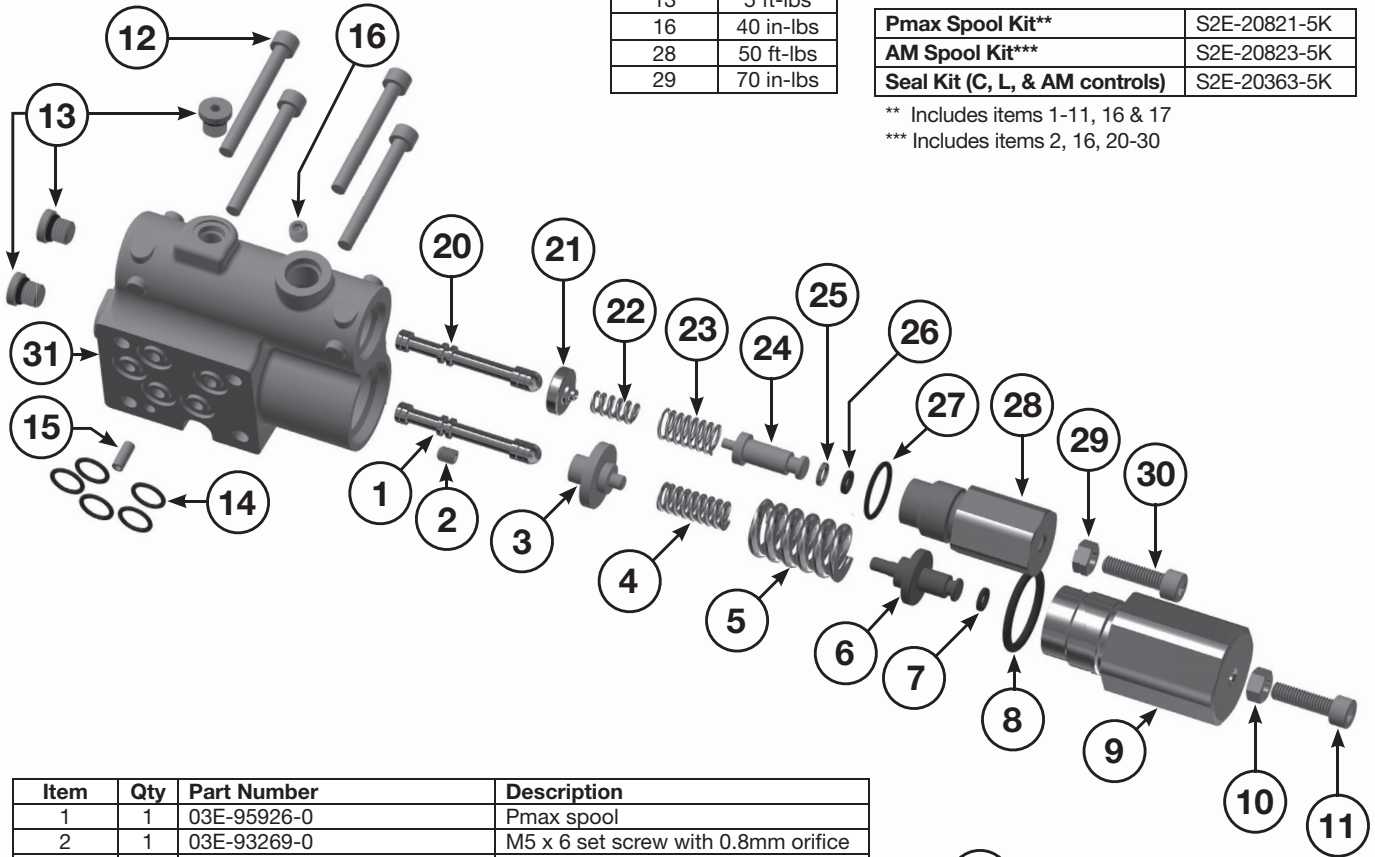

Item	Qty	Part Number	Description
1	1	03E-95926-0	Pmax spool
2	1	03E-93269-0	M5 x 6 set screw with 0.8mm orifice
3	1	Available in kit only	Pmax inner spring guide
4	1	Available in kit only	Pmax inner spring
5	1	Available in kit only	Pmax outer spring
6	1	Available in kit only	Pmax outer spring guide
7*	1	Available in kit only	Pmax outer spring guide O-ring
8*	1	Available in kit only	Pmax main O-ring
9	1	03E-95570-0	Pmax outer cap
10	1	340-00063-0	Pmax adjustment lock nut
11	1	361-08275-0	Pmax M6x22 adjustment screw
12	4	361-07253-8	M5 x 45 SHCS
13*	3	108X2V	SAE Boss Plug & O-ring
14*	5	Available in kit only	Compensator teflon O-ring
15	1	325-36001-0	Compensator M4 x 10 roll pin
16	1	226X56	M6 x 6 set screw
20	1	03E-95860-0	Differential spool
21	1	Available in kit only	Differential inner spring guide
22	1	Available in kit only	Differential inner spring
23	1	Available in kit only	Differential outer spring
24	1	Available in kit only	Differential outer spring guide
25*	1	Available in kit only	Differential inner spring guide O-ring
26*	1	Available in kit only	Differential inner spring guide O-ring
27*	1	Available in kit only	Differential main O-ring
28	1	03E-95572-0	Differential outer cap
29	1	340-00063-0	Differential adjustment lock nut
30	1	361-08275-0	Differential M6x22 adjustment screw
31	1	Not sold separately	Compensator housing

\*Included in C, L, & AM controls seal kit

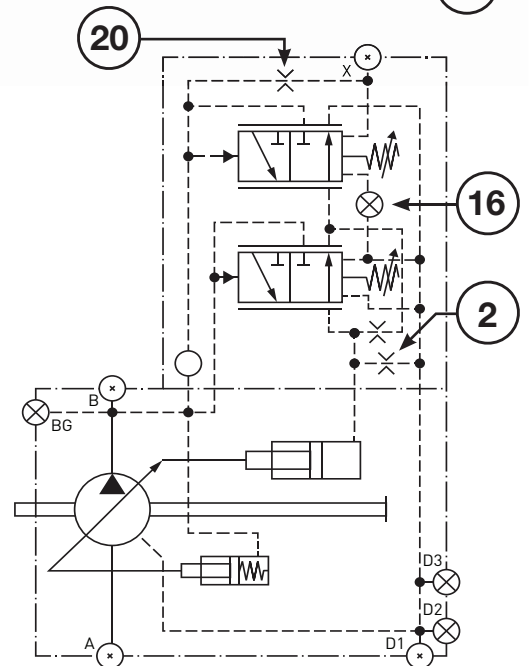

**C0**

Remove	
Item	Description
17	M4 x 5 set screw
18	Boss plug & O-ring - SAE
19	Boss plug & O-ring

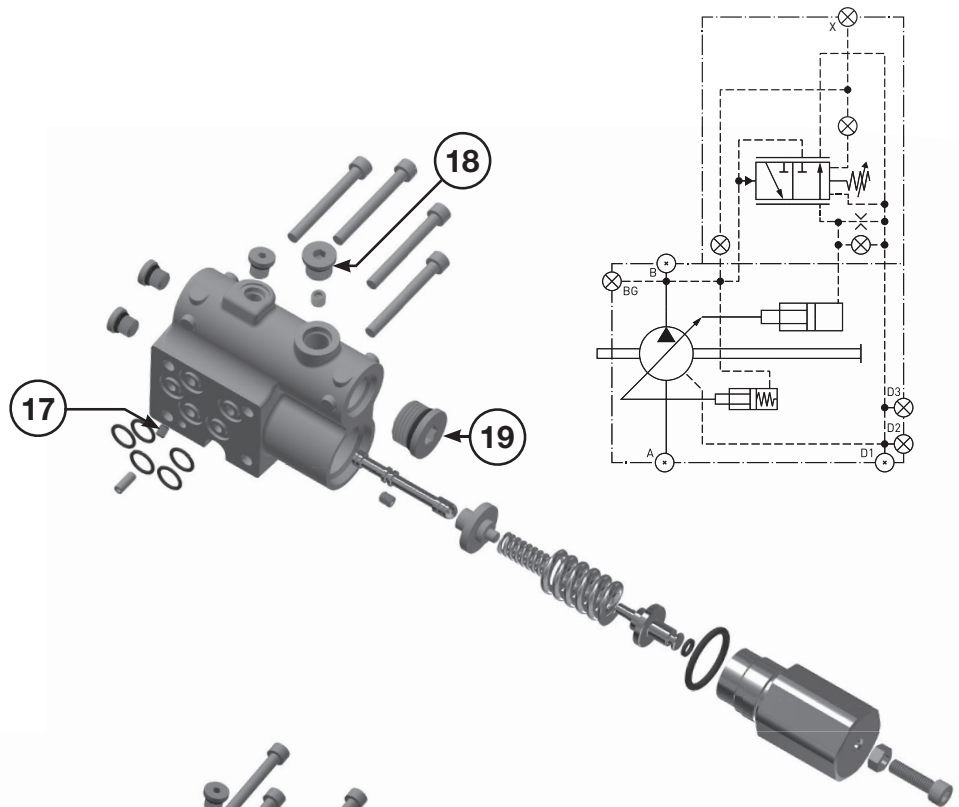

**L0**

Add	
Kit #1 S2E-20463-5K	
Item	Description
21	Differential inner spring guide
22	Differential inner spring
23	Differential outer spring
24	Differential outer spring guide
25	Differential inner spring guide O-ring
26	Differential inner spring guide O-ring
27	Differential main O-ring
28	Differential outer plug
29	Differential adjustment lock nut
30	Differential adjustment screw

Kit #4 S2E-20466-5K	
Item	Description
20	Load sense differential spool

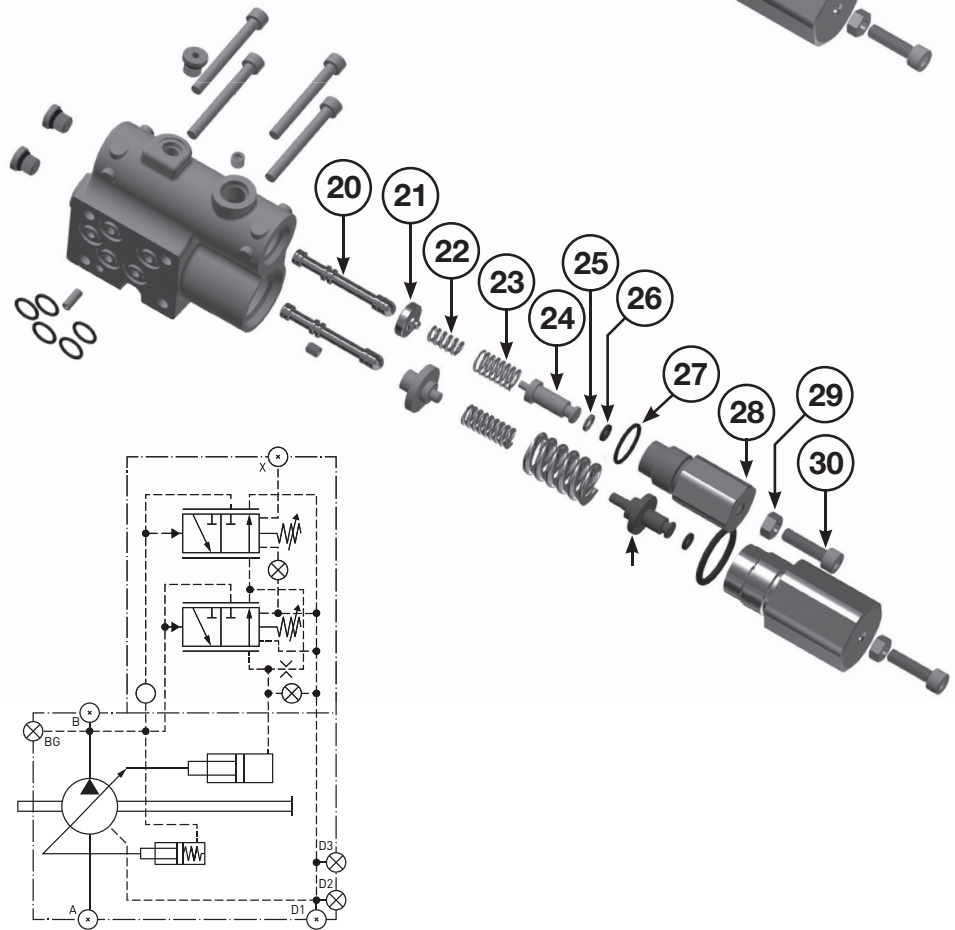

**C0**

Remove	
Item	Description
16	M6 x 6 set screw
17	M4 x 5 set screw
18	Boss plug & O-ring SAE
19	Boss plug & O-ring

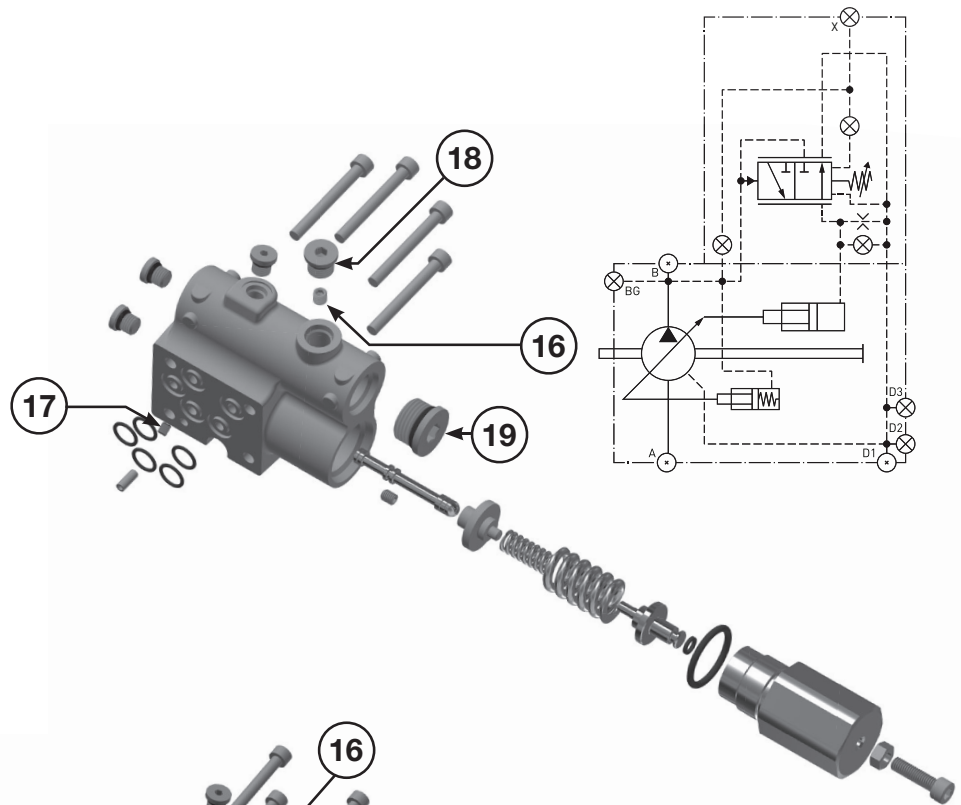

**L2**

Add	
Kit #1 S2E-20463-5K	
Item	Description
21	Differential inner spring guide
22	Differential inner spring
23	Differential outer spring
24	Differential outer spring guide
25	Differential inner spring guide O-ring
26	Differential inner spring guide O-ring
27	Differential main O-ring
28	Differential outer plug
29	Differential adjustment lock nut
30	Differential adjustment screw

Kit #4 S2E-20466-5K	
Item	Description
16	M6 x 6 set screw with 0.4mm orifice
20	Load sense differential spool

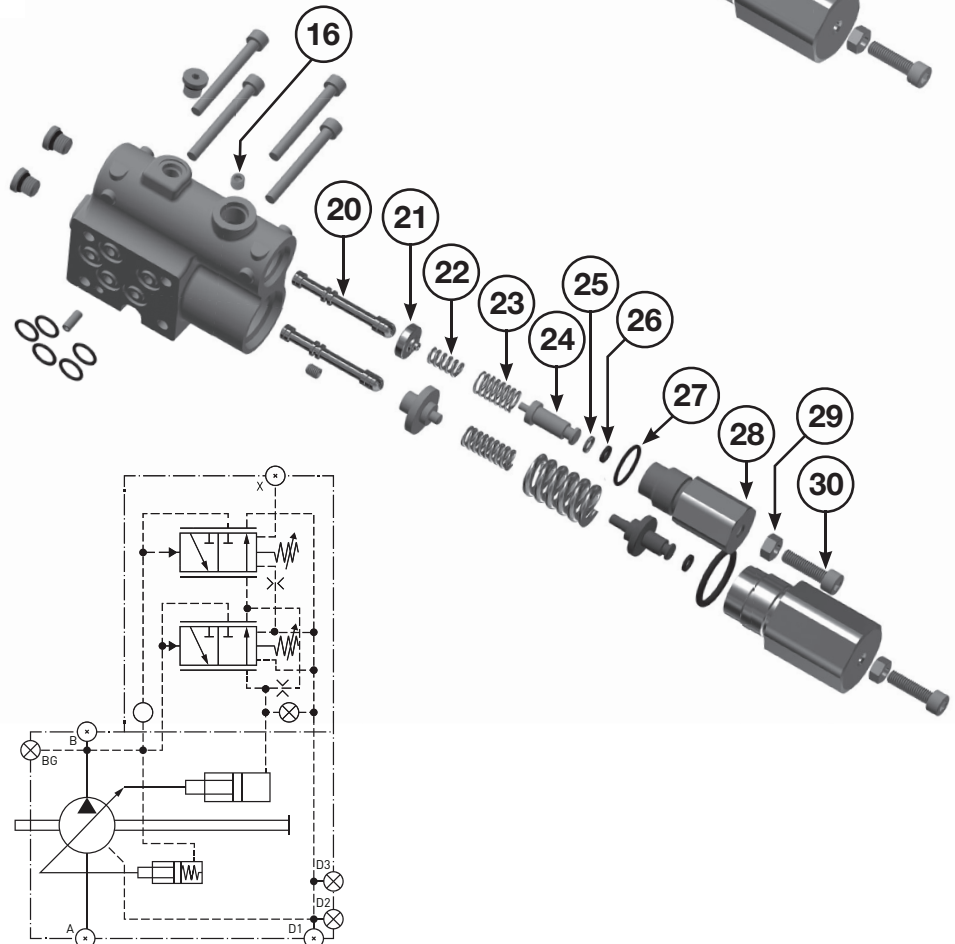

**C0**

Remove	
Item	Description
2	M5 x 6 set screw
17	M4 x 5 set screw
18	Boss plug & O-ring SAE
19	Boss plug & O-ring

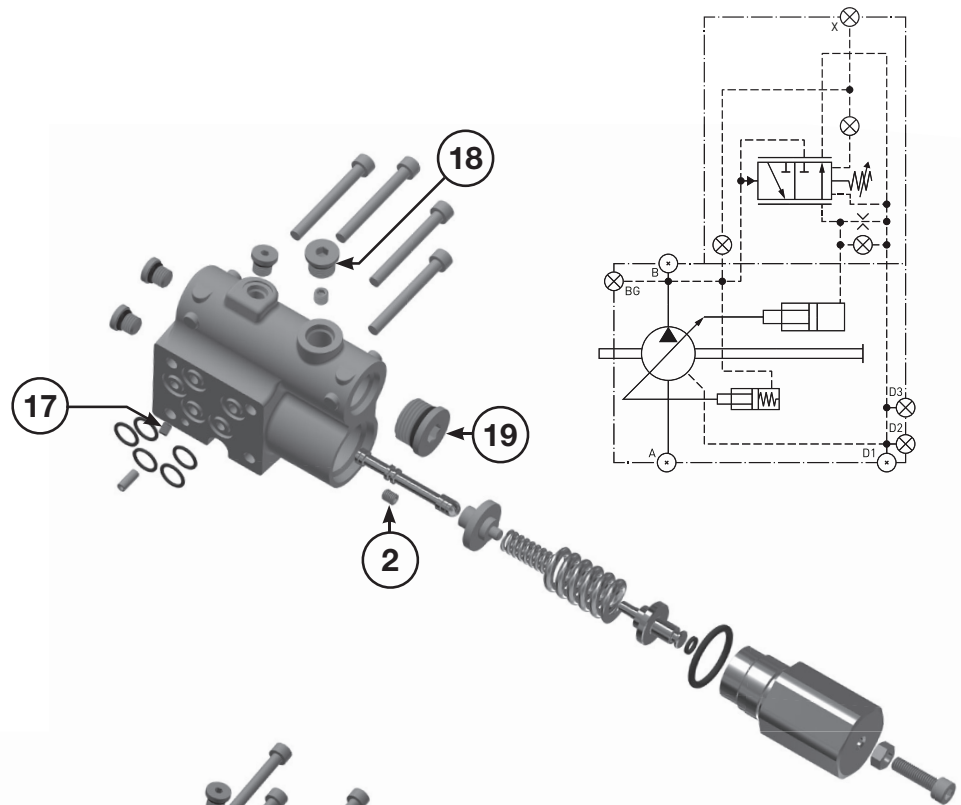

**AM**

Add	
Kit #1 S2E-20463-5K	
Item	Description
21	Differential inner spring guide
22	Differential inner spring
23	Differential outer spring
24	Differential outer spring guide
25	Differential inner spring guide O-ring
26	Differential inner spring guide O-ring
27	Differential main O-ring
28	Differential outer plug
29	Differential adjustment lock nut

Kit #2 S2E-20464-0K	
Item	Description
2	M5 x 6 set screw with 0.8mm orifice
20	AM remote differential spool

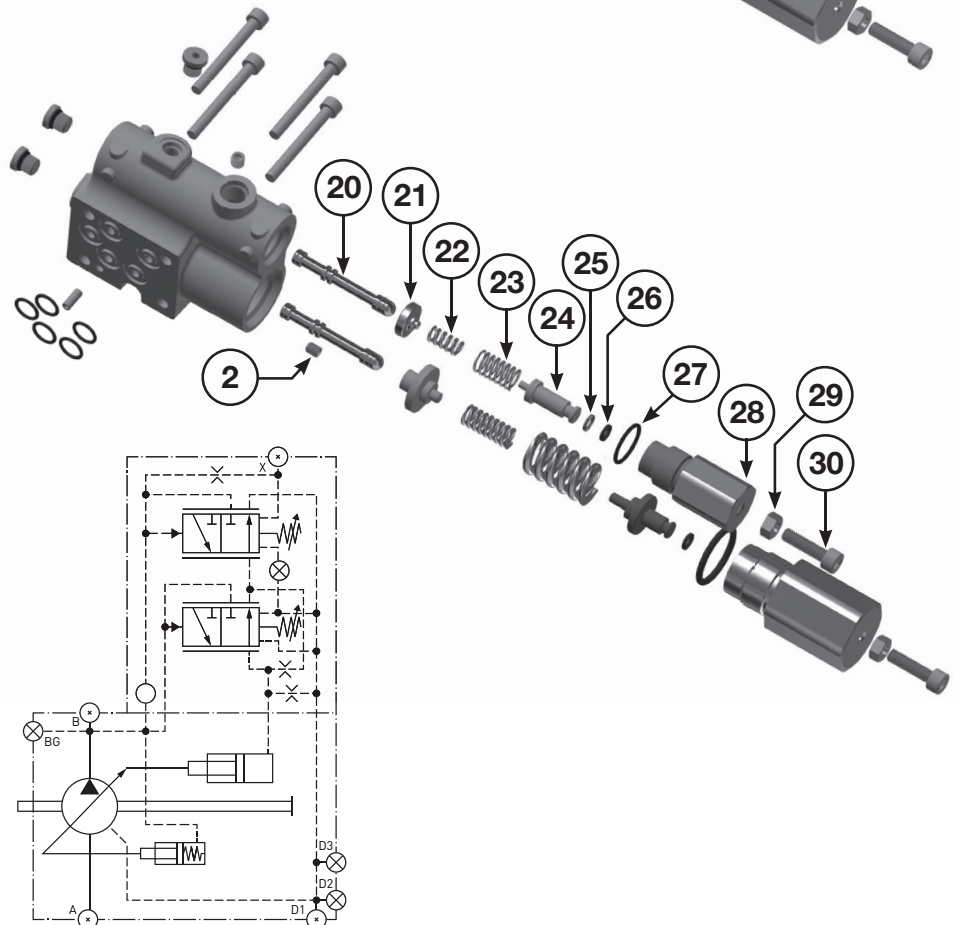



**L0/L2**

Remove	
Item	Description
20	L0 & L2 load sense differential spool
21	Differential inner spring guide
22	Differential inner spring
23	Differential outer spring
24	Differential outer spring guide
25	Differential inner spring guide O-ring
26	Differential inner spring guide O-ring
27	Differential main O-ring
28	Differential outer plug
29	Differential adjustment lock nut
30	Differential adjustment screw

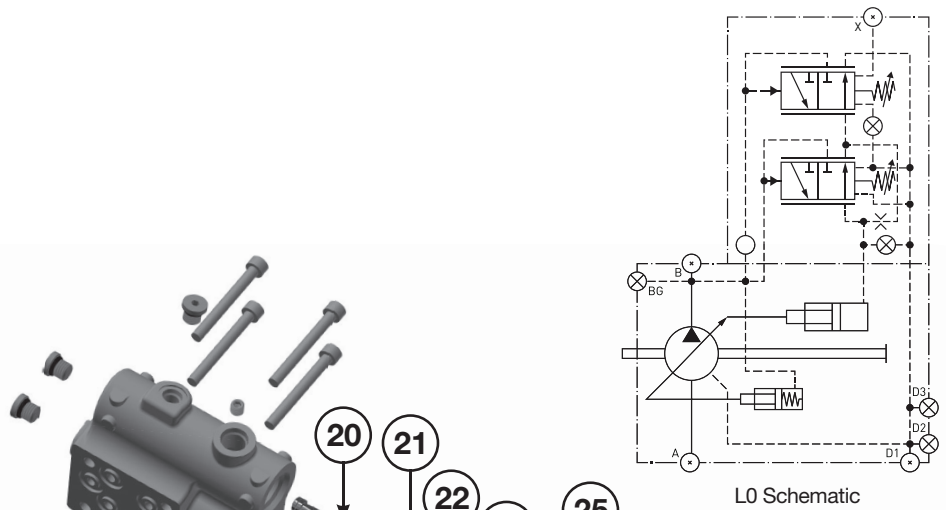

**C0**

Add	
Kit #3 S2E-20465-5K	
Item	Description
17	M4 x 5 set screw
18*	Boss plug & O-ring
19	Boss plug & O-ring

\*Choose SAE, Metric, or BSPP boss plug based on the load sense port type. All three come in Kit #3.

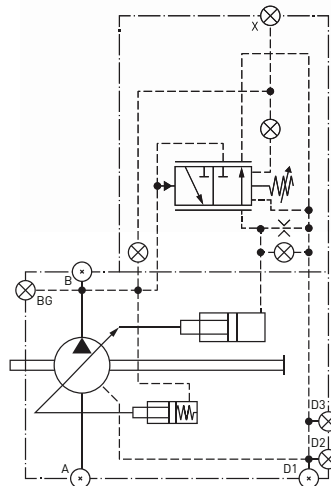
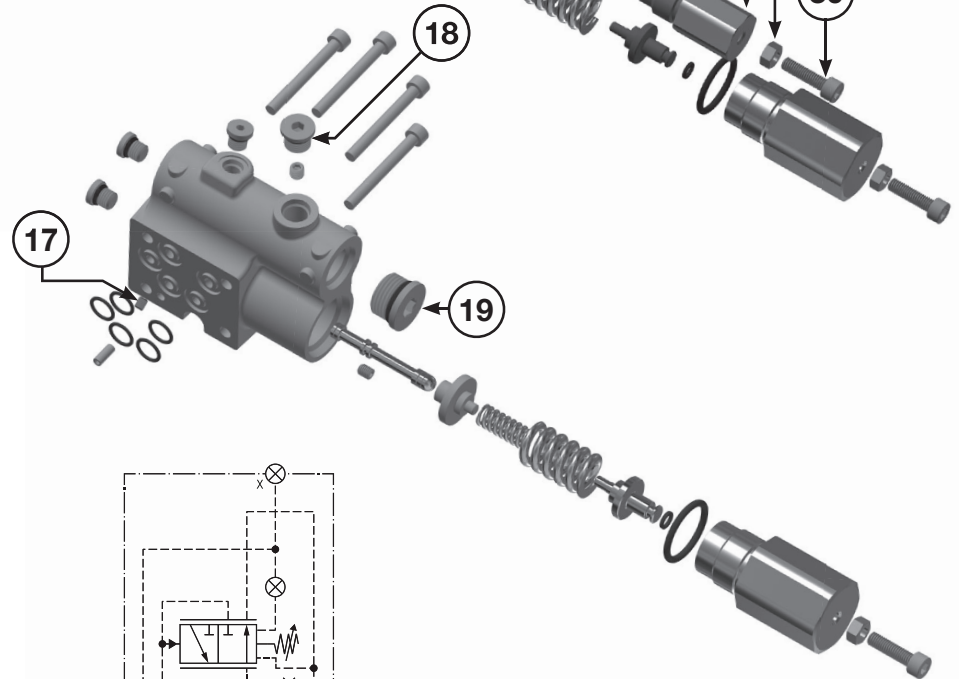

**L0**

Remove	
Item	Description
16	M6 x 6 set screw

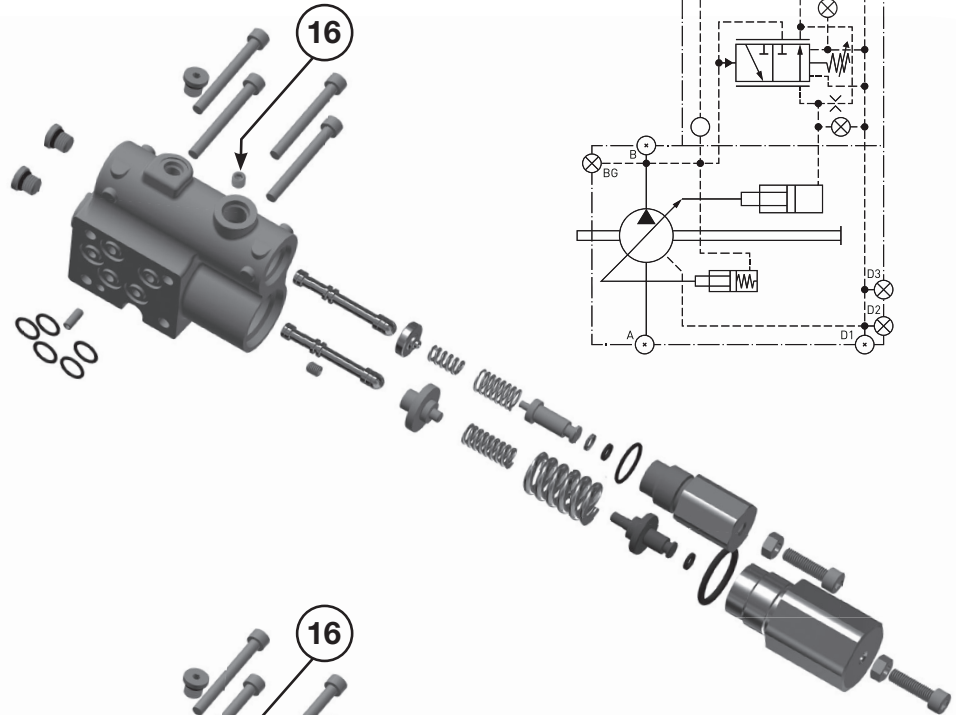

**L2**

Add	
Kit #4 S2E-20466-5K	
Item	Description
16	M6 x 6 set screw with 0.4mm orifice

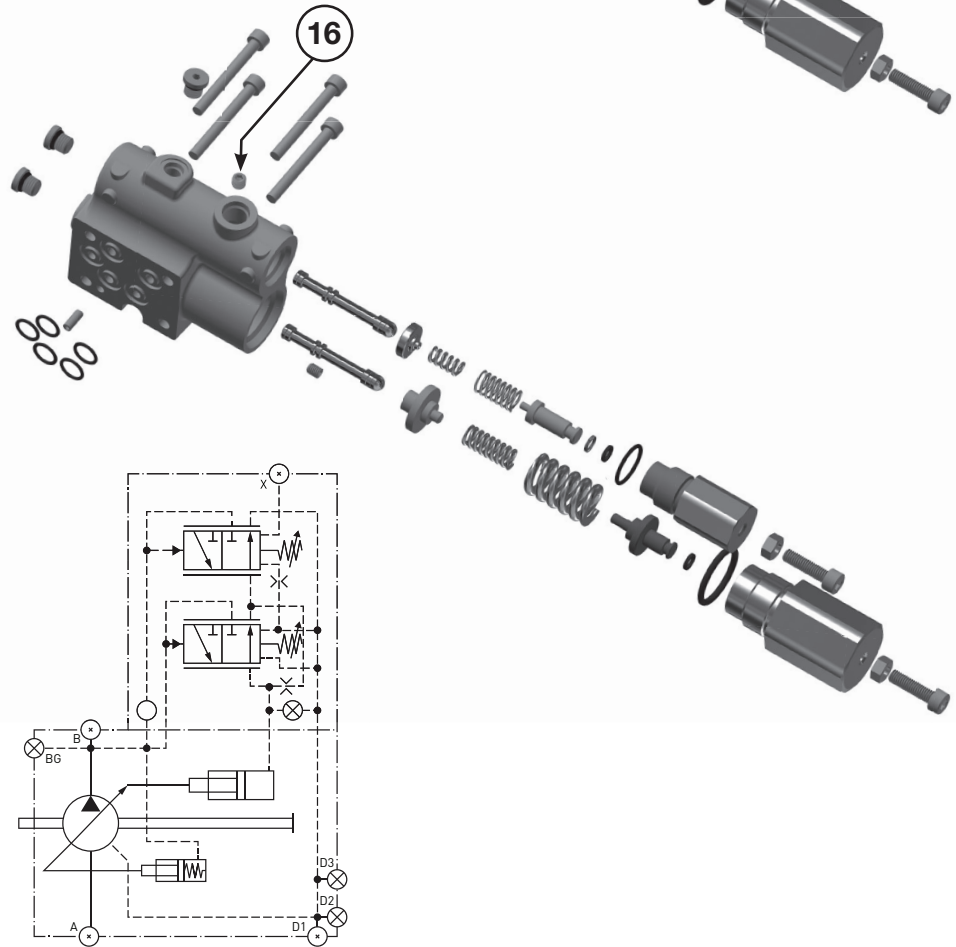

**L2**

Remove	
Item	Description
16	M6 x 6 set screw with 0.4mm orifice

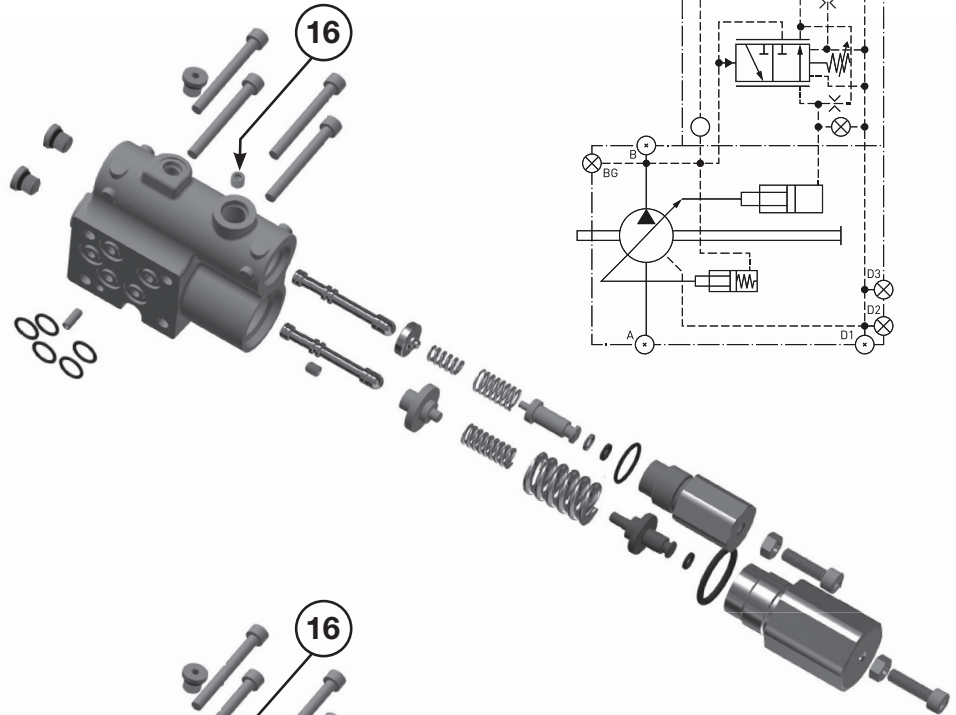

**L0**

Add	
Kit #2 S2E-20464-0K	
Item	Description
16	M6 x 6 set screw

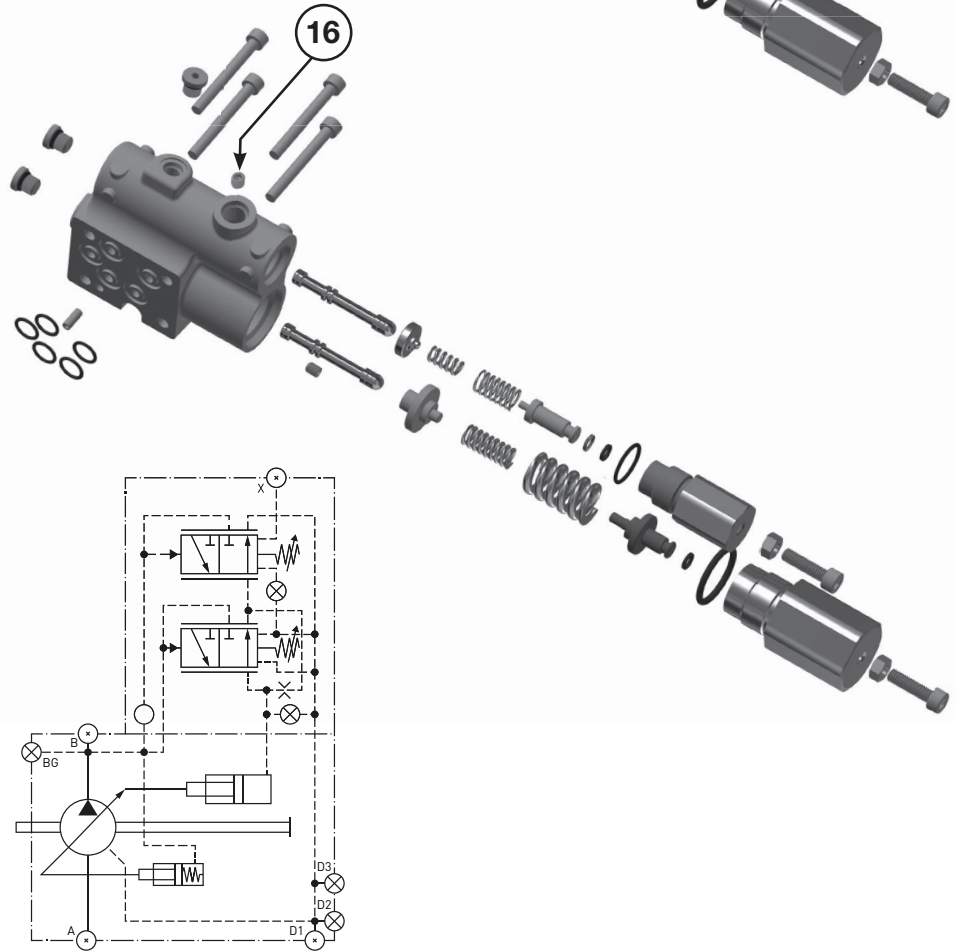

**L0**

Remove	
Item	Description
2	M5 x 6 set screw
20	Load sense differential spool

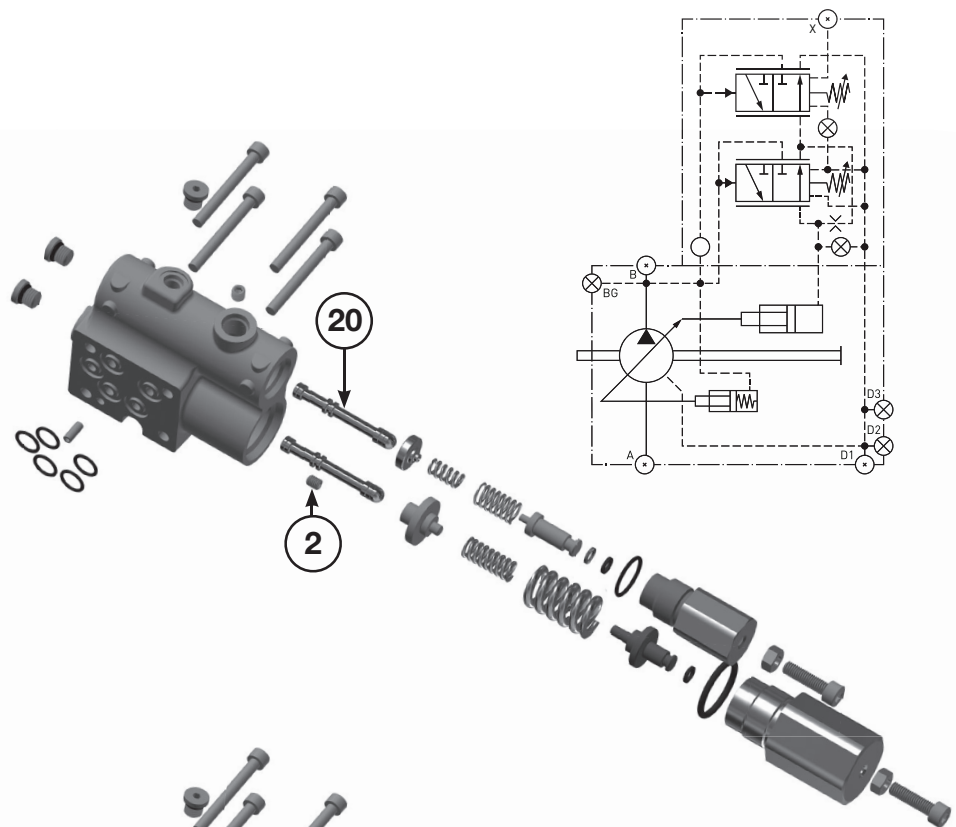

**AM**

Add	
Kit #2 S2E-20464-0K	
Item	Description
2	M5 x 6 set screw with 0.8mm orifice
20	AM remote differential spool

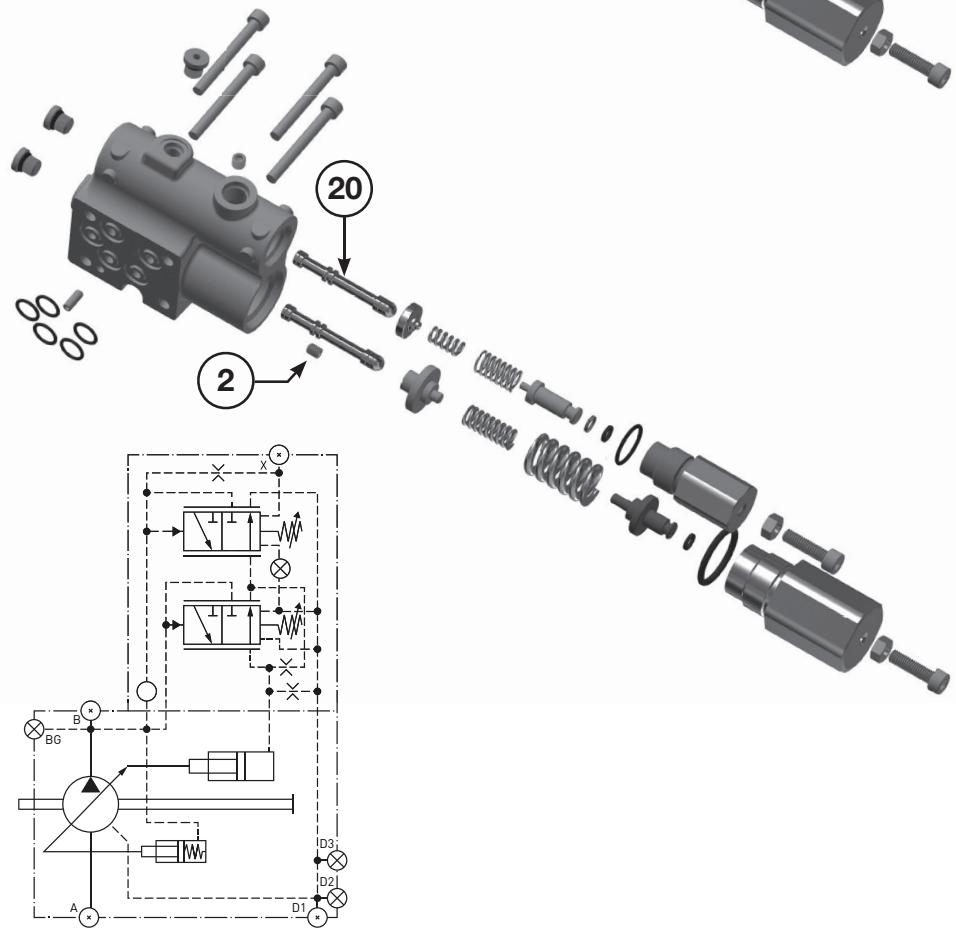

**L2**

Remove	
Item	Description
2	M5 x 6 set screw
16	M6 x 6 set screw with 0.4mm orifice
20	Load sense differential spool

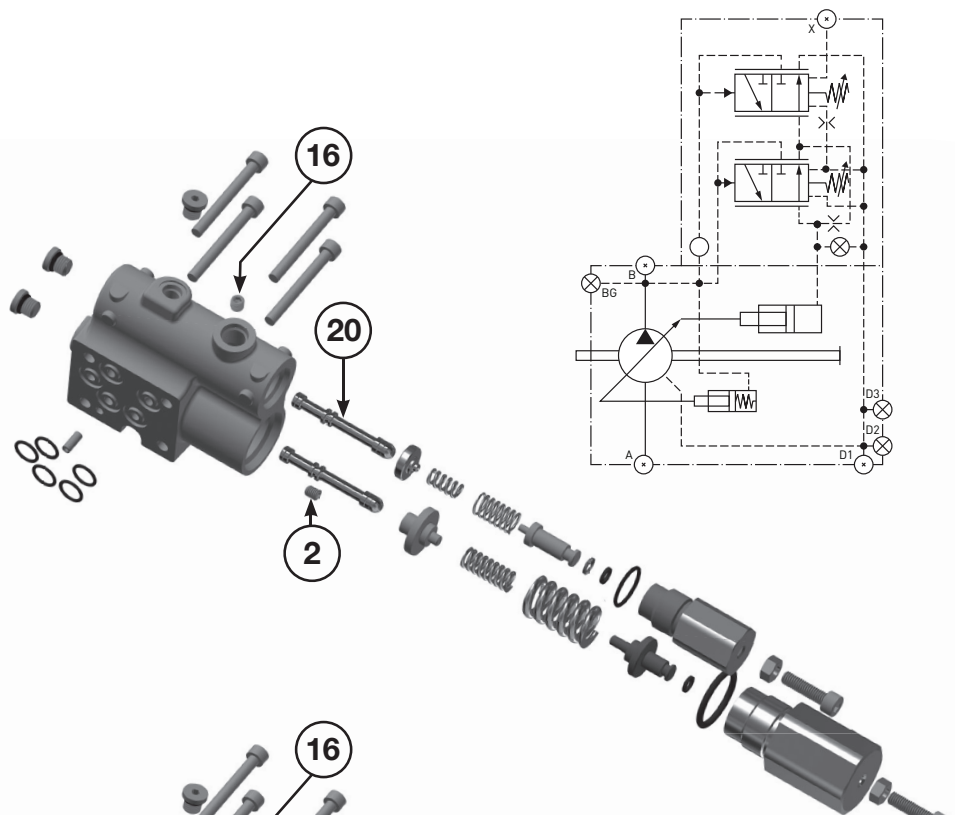

**AM**

Add	
Kit #2 S2E-20464-0K	
Item	Description
2	M5 x 6 set screw with 0.8mm orifice
16	M6 x 6 set screw
20	AM remote differential spool

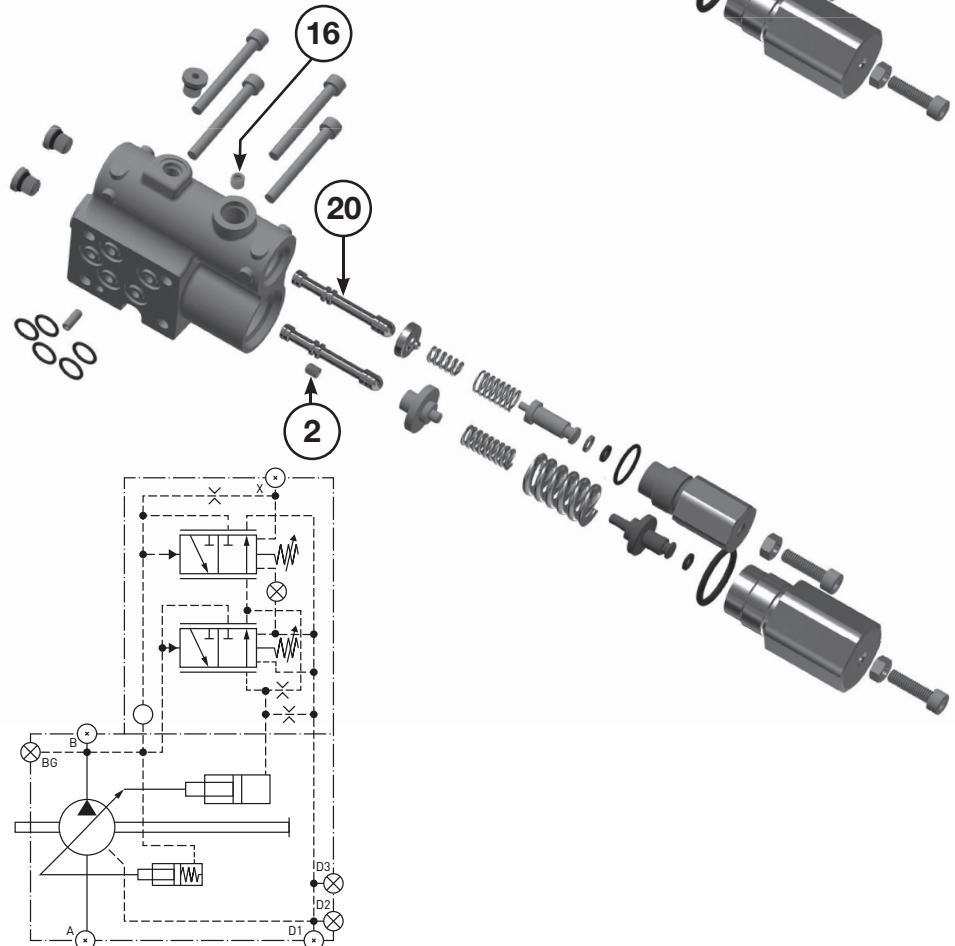



**AM**

Remove	
Item	Description
2	M5 x 6 set screw with 0.8mm orifice
20	L0 & L2 load sense differential spool
21	Differential inner spring guide
22	Differential inner spring
23	Differential outer spring
24	Differential outer spring guide
25	Differential inner spring guide O-ring
26	Differential inner spring guide O-ring
27	Differential main O-ring
28	Differential outer plug
29	Differential adjustment lock nut
30	Differential adjustment screw

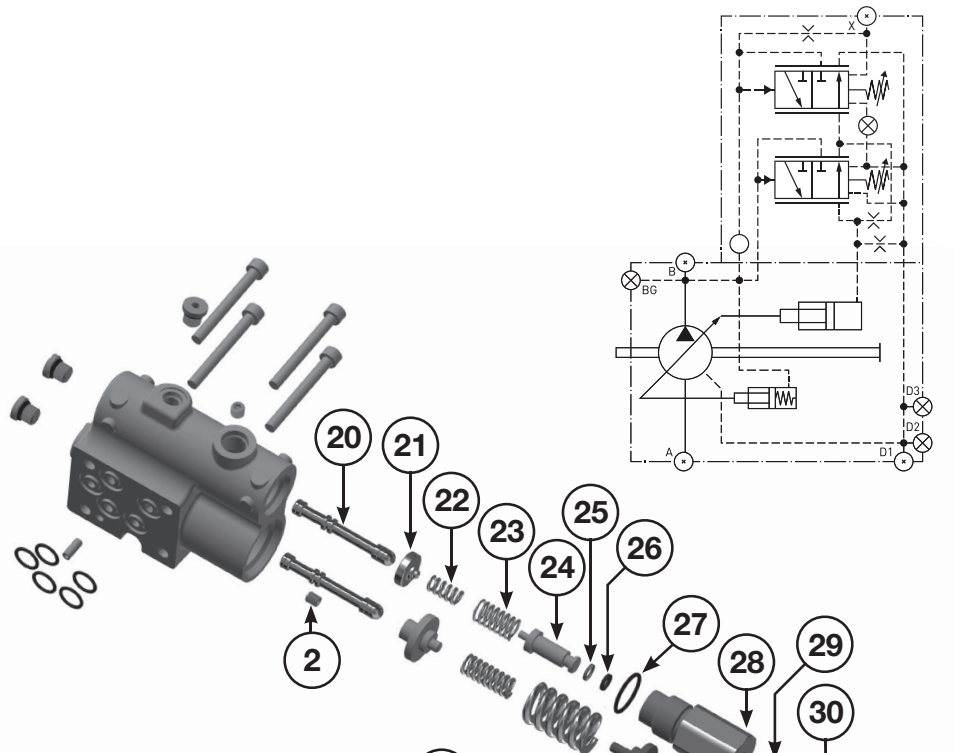

**C0**

Add	
Kit #3 S2E-20465-5K	
Item	Description
2	M5 x 6 set screw
17	M4 x 5 set screw
18*	Boss plug & O-ring
19	Boss plug & O-ring

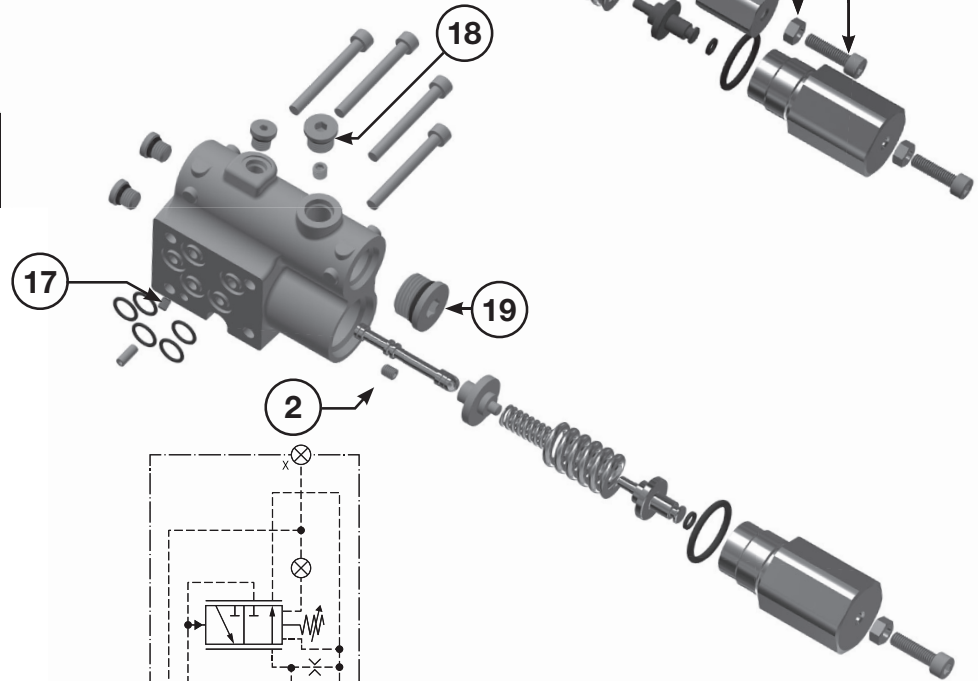

\*Choose SAE, Metric, or BSPP boss plug based on the load sense port type. All three come in Kit #3.

**AM**

Remove	
Item	Description
2	M5 x 6 set screw with 0.8mm orifice
20	AM remote differential spool

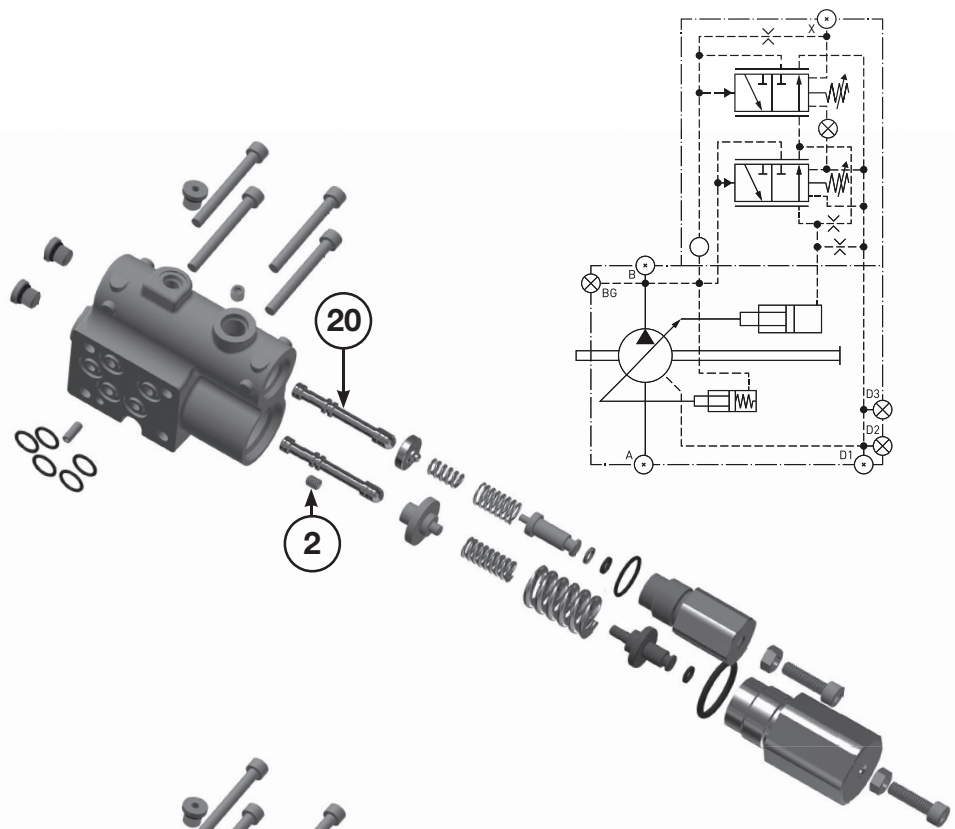

**L0**

Add	
Kit #4 S2E-20466-5K	
Item	Description
2	M5 x 6 set screw
20	Load sense differential spool

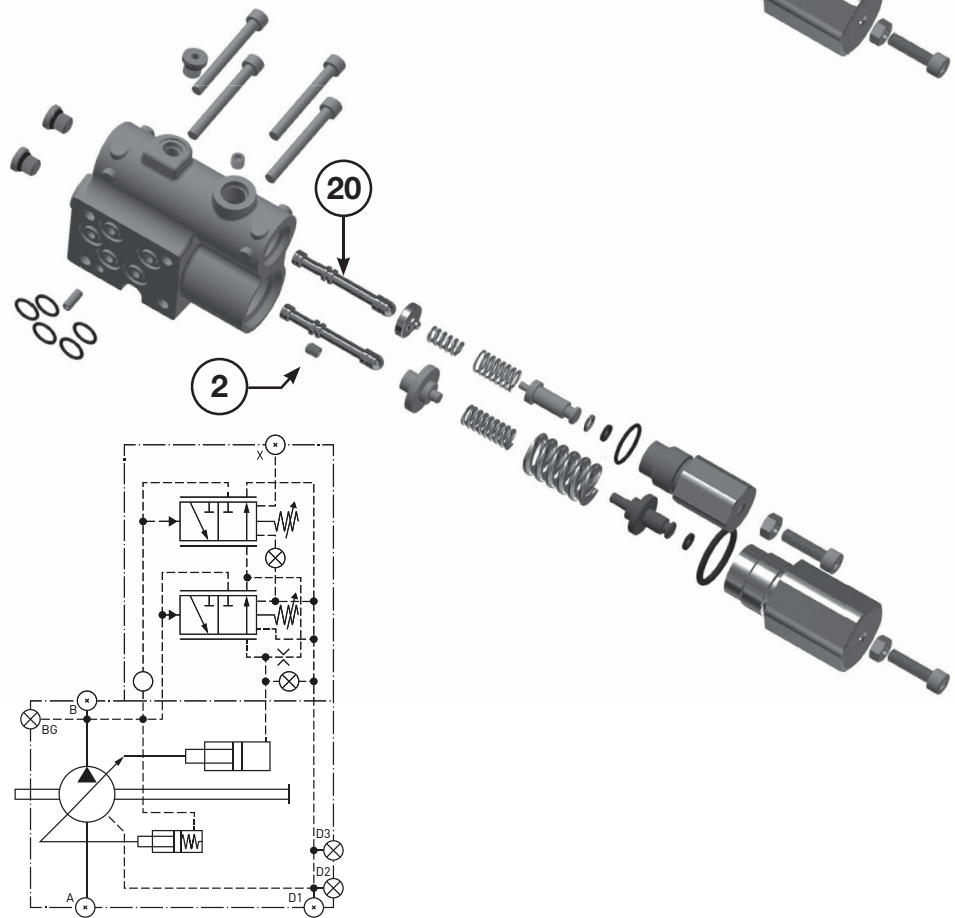

**AM**

Remove	
Item	Description
2	M5 x 6 set screw with 0.8mm orifice
16	M6 x 6 set screw
20	AM remote differential spool

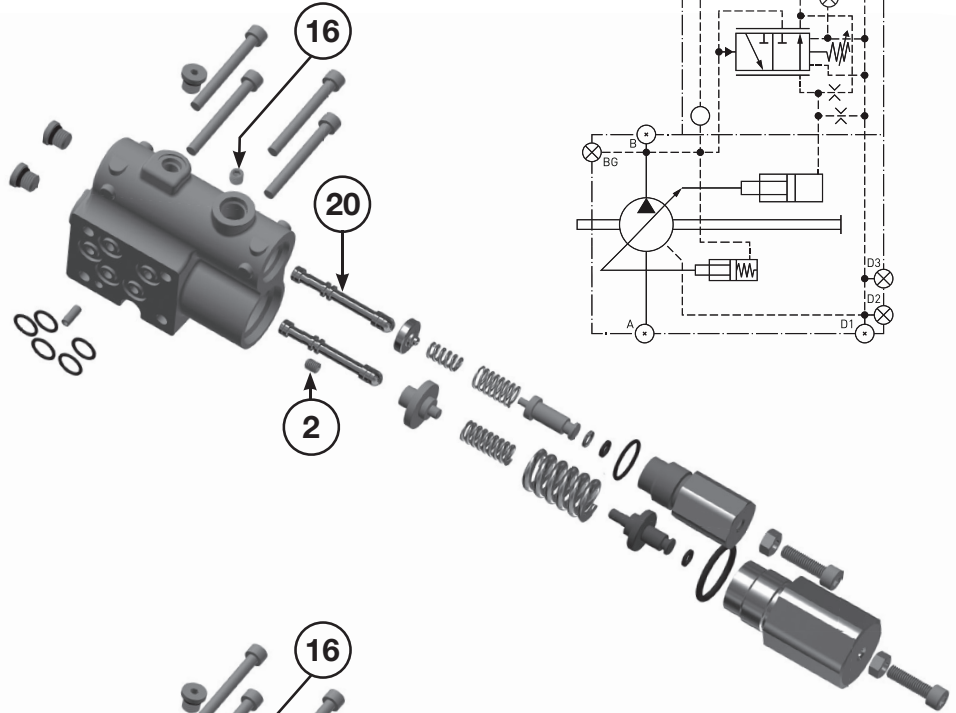

**L2**

Add	
Kit #4 S2E-20466-5K	
Item	Description
2	M5 x 6 set screw
16	M6 x 6 set screw with 0.4mm orifice
20	Load sense differential spool

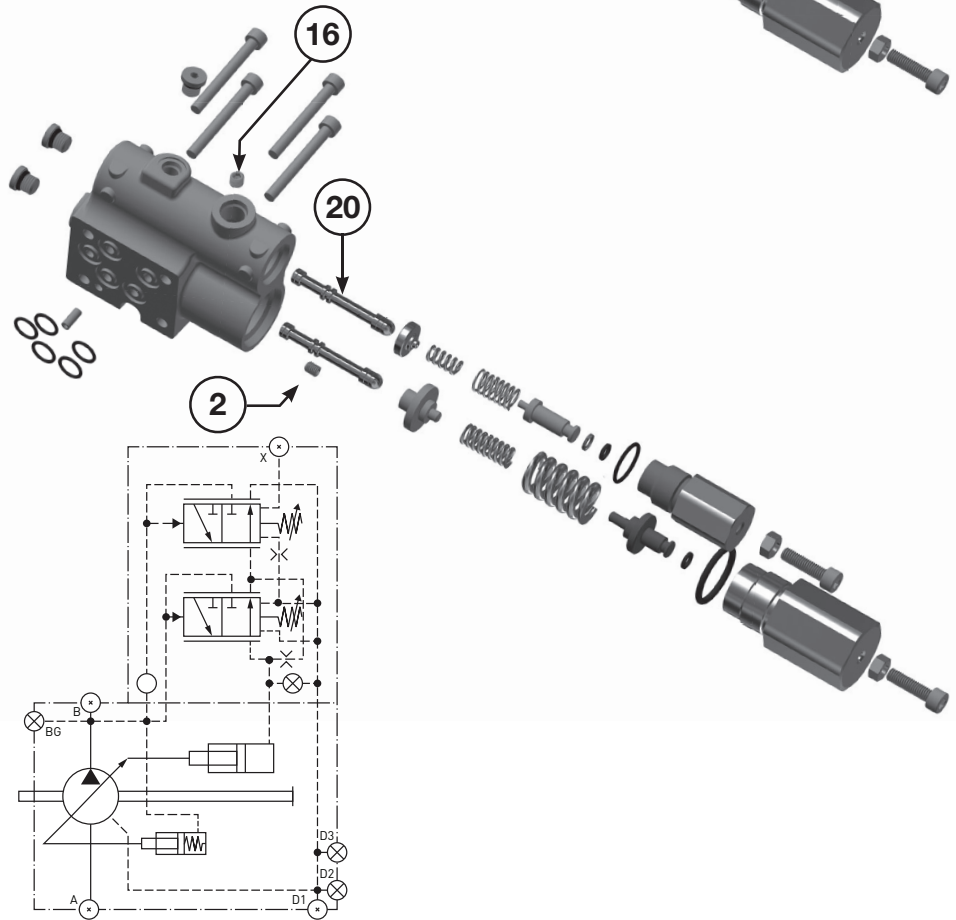

**AN B-mod Control**

**Medium Pressure Axial Piston Pumps  
P1/PD B-mod Service Information**

Item	Torque
4	5 ft-lbs
5	15 ft-lbs
9	50 in-lbs
10	35 in-lbs
11	35 in-lbs
12	35 in-lbs
13	35 in-lbs

**AN Service Kits**

Part Number	Description
S5E-10738-5K	B-mod AN Service Kit*
S5E-10739-5K	B-mod AN Service Kit for CW A-mod Pump**
S5E-10740-5K	B-mod AN Service Kit for CCW A-mod Pump**

\*Includes all items shown on exploded view

\*\*Includes all items shown on exploded view plus adapter block assembly called out on page 40

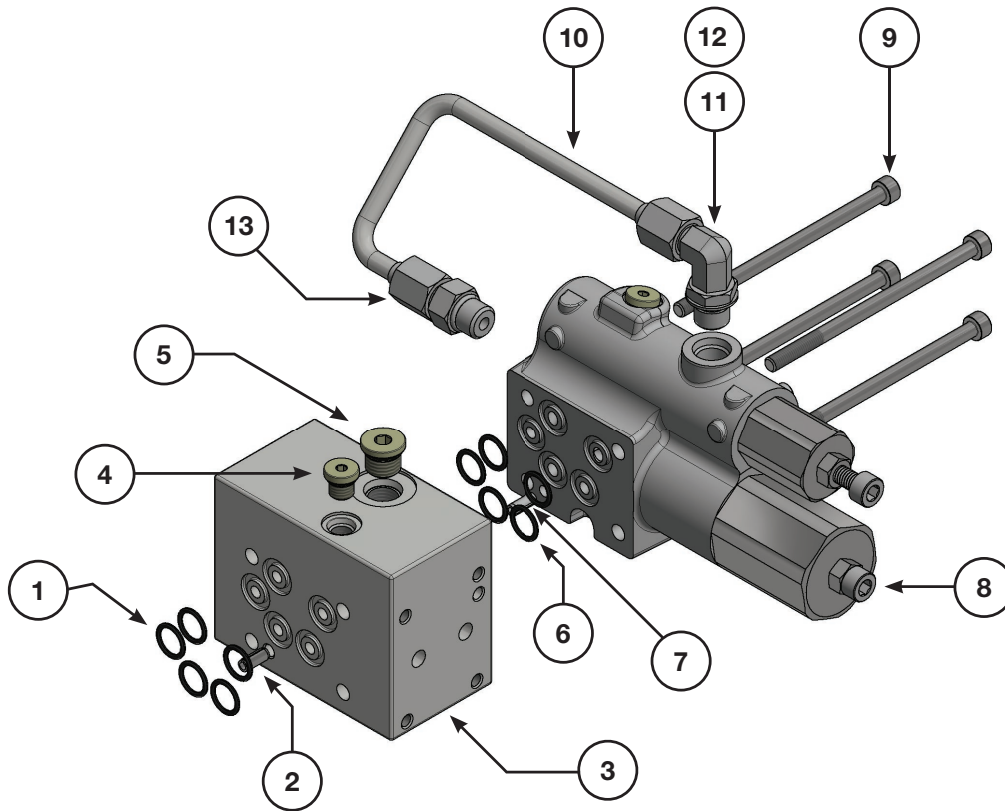

Item	Qty	Part Number	Description
1	5	Seal Kit Only	ARP-012 Teflon O-rings (included in #3)
2	1	325-36001-0	Locating Pin (included in #3)
3	1	S5E-10025-5	Adapter Block
4	1	108X2V	SAE -2 Hex Plug & o-ring (included in #3)
5	1	108X4V	SAE -4 Hex Plug & o-ring (included in #3)
6	5	Seal Kit Only	ARP-012 Teflon O-rings (included in #8)
7	1	325-36001-0	Locating Pin (included in #8)
8	1	See Page 17	AM Compensator
9	4	210X115	M5x90 SHCS
10	1	S5E-10024-0	AN/AE/AF Tubing
11	1	494-15016-0	Elbow Fitting - #4 C5X-S
12	1	Seal Kit Only	Elbow Fitting FKM o-ring
13	1	4-F50X-SV	Fitting with FKM o-ring

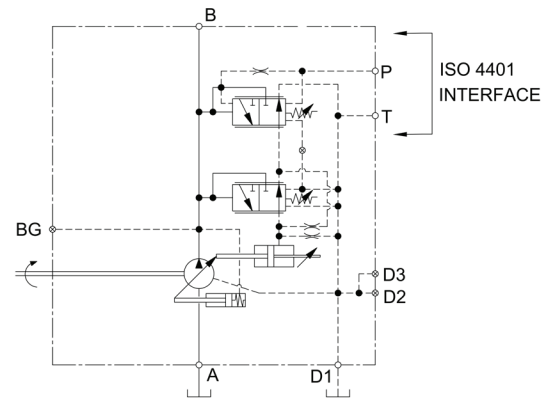

**LOT & AMT B-Mod Controls**

Item	Torque
4	5 ft-lbs
5	15 ft-lbs
9	50 in-lbs
11	35 in-lbs
14	35 in-lbs
15	35 in-lbs
16	35 in-lbs
17	35 in-lbs
18	35 in-lbs
20	35 in-lbs

Note: Parts shown are for the 45 & 60cc. The adapter block assembly (#1-5), cover plate assembly (#19-22), and elbow (#12 & 16) are not part of the 75-140cc L0 or AM torque limiter assembly.

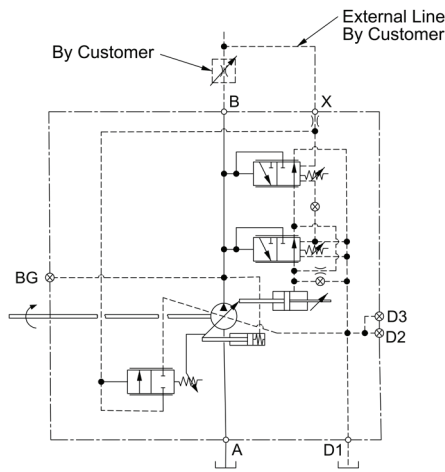
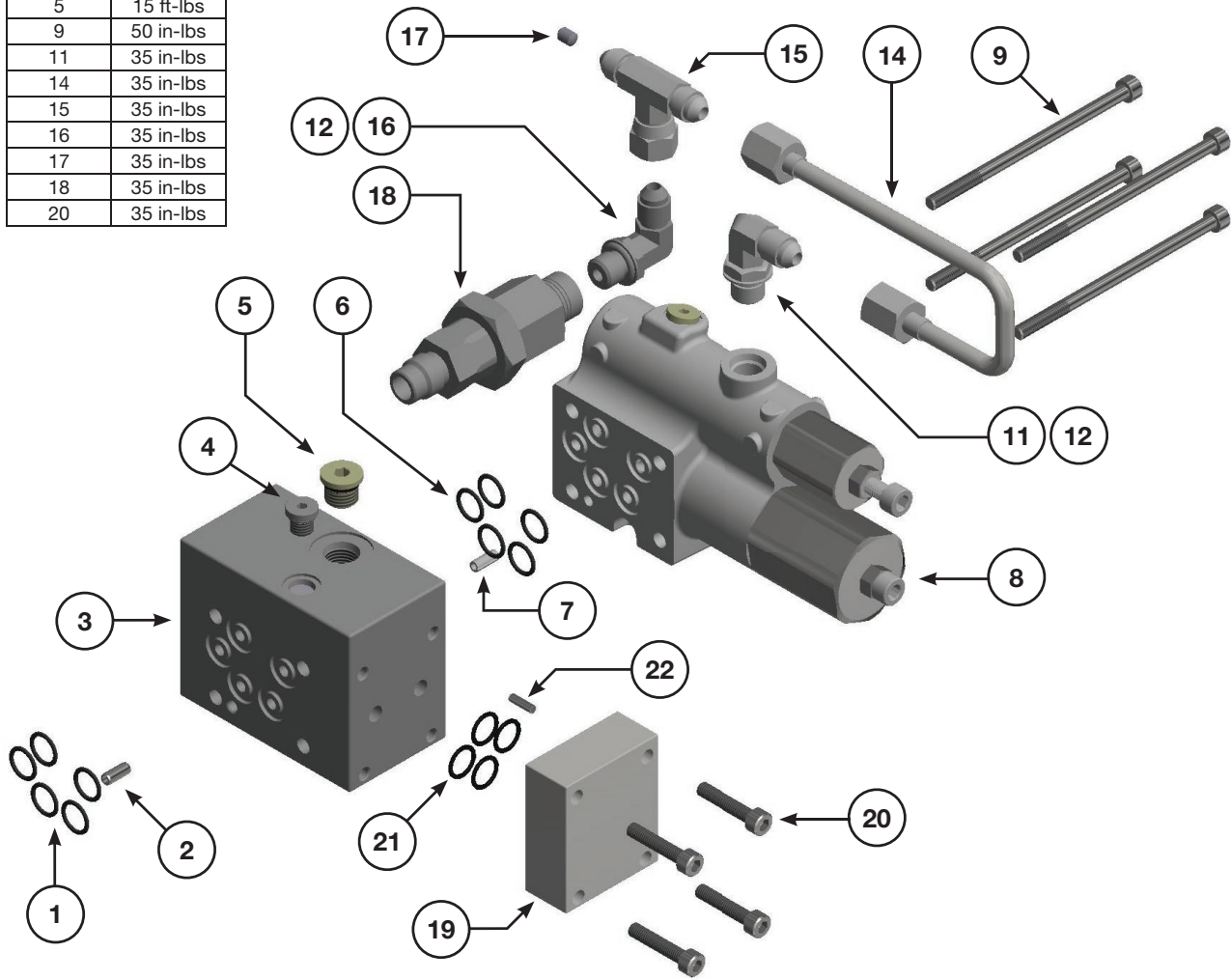

**LOT Torque Limiter**

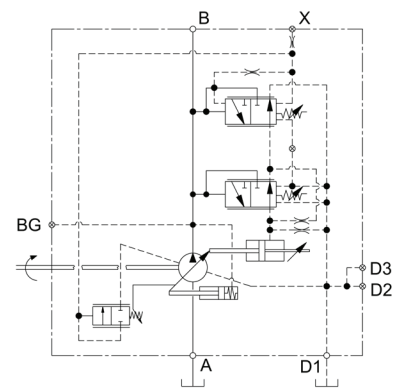

**AMT Torque Limiter**



**L0T & AMT B-Mod Controls Parts List****Medium Pressure Axial Piston Pumps  
P1/PD B-mod Service Information**

Item	Qty	Part Number	Description
1*	5	Seal Kit Only	ARP-012 Teflon O-rings (included in #3)
2*	1	325-36001-0	Locating Pin (included in #3)
3*	1	S5E-10025-5	Adapter Block (Not included in 75-140cc)
4*	1	108X2V	SAE -2 Hex Plug & o-ring (included in #3)
5*	2	108X4V	SAE -4 Hex Plug & o-ring (included in #3)
6	5	Seal Kit Only	ARP-012 Teflon O-rings (included in #8)
7	1	325-36001-0	Locating Pin (included in #8)
8	1	See Page 15	L0 Compensator
		See Page 17	AM Compensator
9	4	210X115	M5x90 SHCS (45 & 60cc)
		361-07253-8	M5x45 SHCS (75-140cc)(included in #8)
11	1	494-15016-0	UMC elbow fitting
12	2	Seal Kit Only	FKM Elbow O-ring (Only 1 pc included in 75-140cc)
14	1	S5E-10227-0	Tubing CW 45cc
		S5E-10228-0	Tubing CCW 45cc
		S5E-10229-0	Tubing CW 60cc
		S5E-10230-0	Tubing CCW 60cc
		S2E-20179-0	Tubing CW 75cc
		S2E-20178-0	Tubing CCW 75cc
		S2E-20181-0	Tubing CW 100cc
		S2E-20180-0	Tubing CCW 100cc
		S2E-20183-0	Tubing CW 140cc
S2E-20182-0	Tubing CCW 140cc		
15	1	03E-97837-0	Tee (45 & 60cc)
		039-93646-0	Tee (75-140cc)
16	1	494-15016-0	Torque Limiter elbow fitting (Not included on 75-140cc)
17	1	035-40489-0	SAE #10-24 set screw with 0.8mm orifice
18	1	S2E-18706-5	Torque Limiter
19*	1	518-00243-0	Cover plate with 4 screws (Not included on 75-140cc)
20*	1	Included in #19	M5x25 SHCS
21*	4	Seal Kit Only	ARP-012 FKM O-rings (included in #19)
22*	1	Included in #19	Locating Pin

\*Included with 45 & 60cc pumps only

<b>B-mod Torque Limiter Control Kits</b>	<b>045</b>	<b>060</b>	<b>075/085</b>	<b>100</b>	<b>140</b>
Torque Limiter Kit for L0, AM Controls - CCW Rotation	S5E-10220-5	S5E-10222-5	S2E-20297-5	S2E-20215-5	S2E-20252-5
Torque Limiter Kit for L0, AM Controls - CW Rotation	S5E-10219-5	S5E-10221-5	S2E-20296-5	S2E-20290-5	S2E-20243-5

Torque Limiter Kits include cartridge assembly, tubing and fittings.

**ANT B-mod Control**

Item	Torque
4	5 ft-lbs
5	15 ft-lbs
9	50 in-lbs
10	35 in-lbs
11	35 in-lbs
13	35 in-lbs
14	35 in-lbs
15	35 in-lbs
16	35 in-lbs
18	35 in-lbs

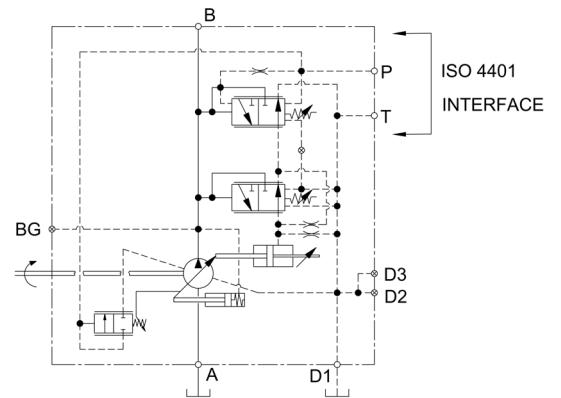
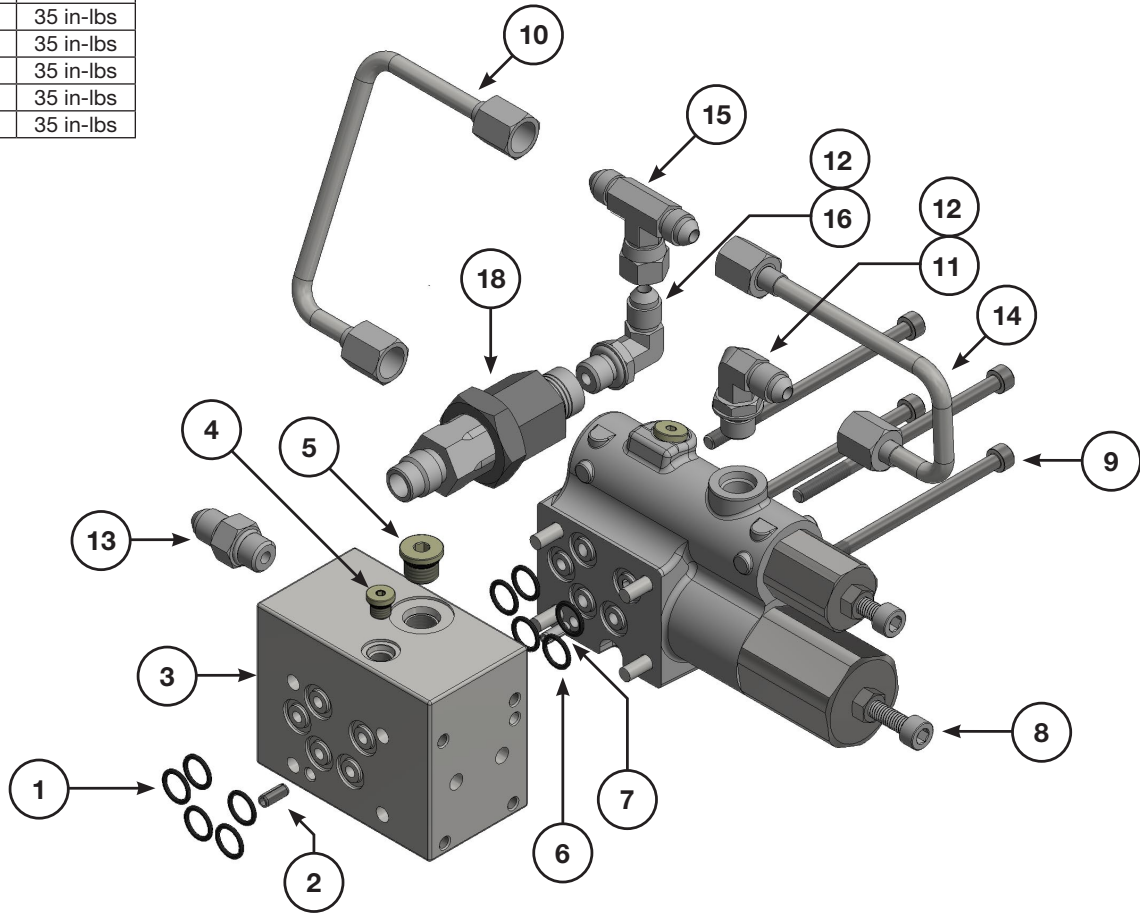

**ANT Torque Limiter**

**ANT B-mod Control Parts List****Medium Pressure Axial Piston Pumps  
P1/PD B-mod Service Information**

Item	Qty	Part Number	Description
1	1	Seal Kit Only	ARP-012 Teflon O-rings (included in #3)
2	1	325-36001-0	Locating Pin (included in #3)
3	1	S5E-10025-5	Adapter Block
4	1	108X2V	SAE -2 Hex Plug & o-ring (included in #3)
5	1	108X4V	SAE -4 Hex Plug & o-ring (included in #3)
6	5	Seal Kit Only	ARP-012 Teflon O-rings (included in #8)
7	1	325-36001-0	Locating Pin (included in #8)
8	1	See Page 17	AM Compensator
9	4	210X115	M5x90 SHCS
10	1	S5E-10261-0	Tubing - Block to TL (45cc/CW)
		S5E-10262-0	Tubing - Block to TL (45cc/CCW)
		S5E-10263-0	Tubing - Block to TL (60cc/CW)
		S5E-10264-0	Tubing - Block to TL (60cc/CCW)
		S5E-10265-0	Tubing - Block to TL (75-85cc/CW)
		S5E-10266-0	Tubing - Block to TL (75-85cc/CCW)
		S5E-10267-0	Tubing - Block to TL (100cc/CW)
		S5E-10268-0	Tubing - Block to TL (100cc/CCW)
		S5E-10270-0	Tubing - Block to TL (140cc/CCW)
11	1	494-15016-0	UMC elbow fitting
12	2	Seal Kit Only	FKM O-ring
13	1	4-F50X-SV	Fitting with FKM o-ring
14	1	S5E-10227-0	Tubing - UMC to TL (45cc/CW)
		S5E-10228-0	Tubing - UMC to TL (45cc/CCW)
		S5E-10229-0	Tubing - UMC to TL (60cc/CW)
		S5E-10230-0	Tubing - UMC to TL (60cc/CCW)
		S5E-10749-0	Tubing - UMC to TL (75-85cc/CW)
		S5E-10750-0	Tubing - UMC to TL (75-85cc/CCW)
		S5E-10751-0	Tubing - UMC to TL (100cc/CW)
		S5E-10752-0	Tubing - UMC to TL (100cc/CCW)
		S5E-10754-0	Tubing - UMC to TL (140cc/CCW)
15	1	4 S6X-S	Tee
16	1	494-15016-0	Torque Limiter elbow fitting
18	1	S2E-18706-5	Torque Limiter (45 & 60cc)

<b>B-mod ANT Control Kits</b>	<b>045</b>	<b>060</b>	<b>075/085</b>	<b>100</b>	<b>140</b>
Torque Limiter Kit for ANT Controls - CCW Rotation	S5E-10252-5	S5E-10254-5	S5E-10256-5	S5E-10258-5	S5E-10260-5
Torque Limiter Kit for ANT Controls - CW Rotation	S5E-10251-5	S5E-10253-5	S5E-10255-5	S5E-10257-5	S5E-10259-5

Kits includes everything but items #6, 7, &amp; 8

Control Assembly Part Numbers	
C03	S2E-20764-5T
C06	S2E-20765-5T
L03 SAE	S2E-20756-5T
L03 BSPP	S2E-20757-5T
L03 Metric	S2E-20758-5T
L06 SAE	S2E-20759-5T
L06 BSPP	S2E-20760-5T
L06 Metric	S2E-20761-5T

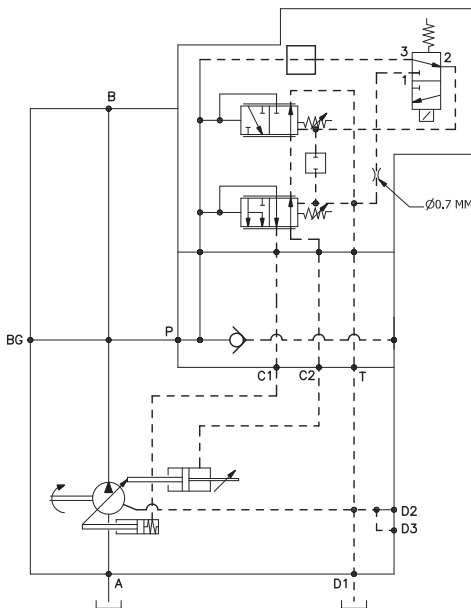
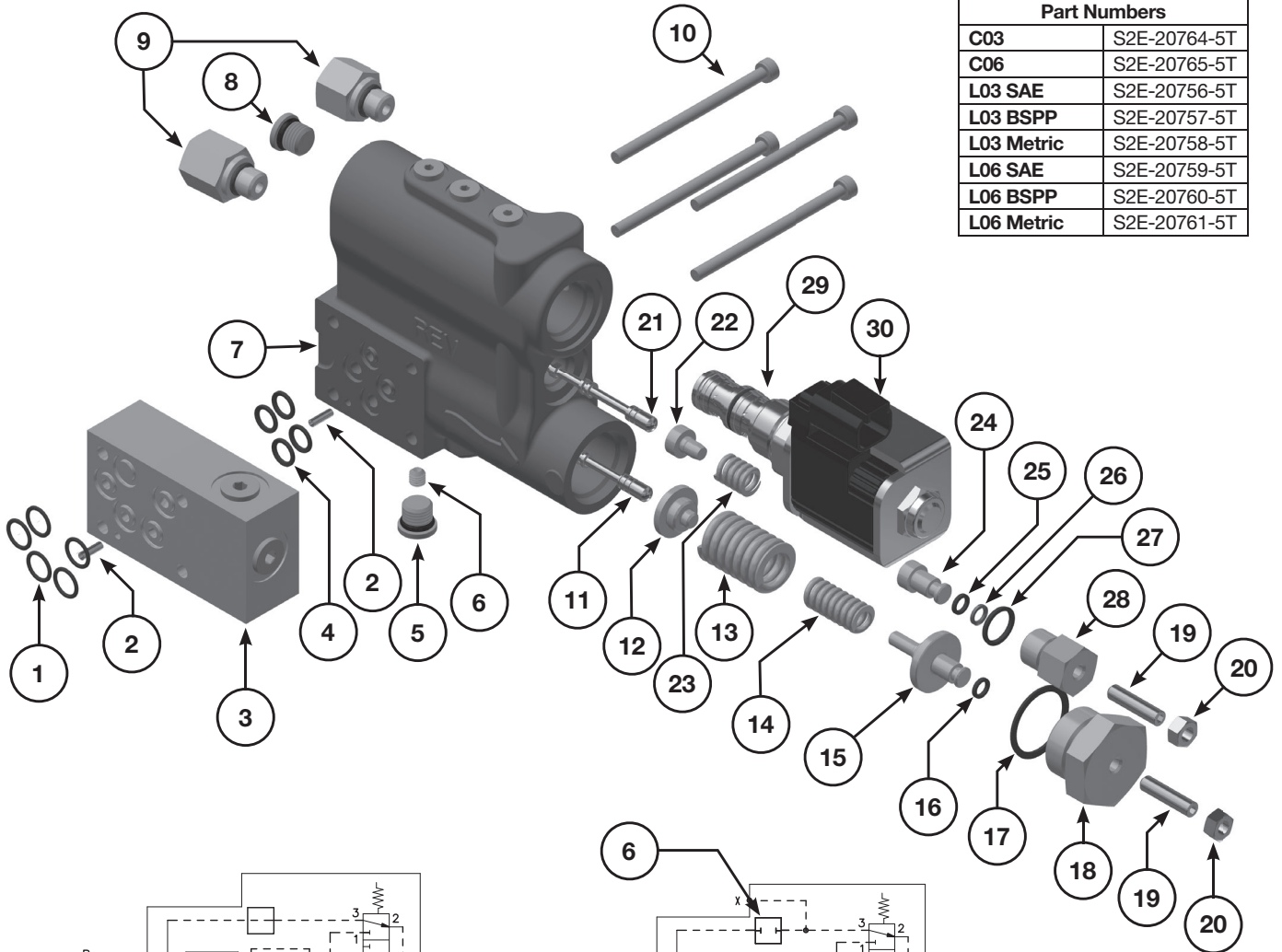

**C0\* Pressure Compensator Control  
 with Unloading Valve**

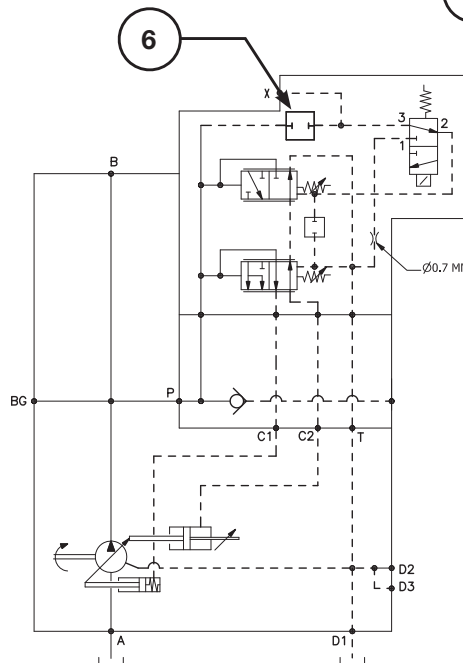

**L0\* Load Sense Control  
 with Unloading Valve**

Item	Torque
5	15 ft-lbs
6	40 in lbs
8	15 ft-lbs
9	15 ft-lbs
10	5 ft lbs
18	85 ft lbs
20	70 in lbs
28	50 ft lbs
29	50 ft lbs



**C03/6 & L03/6 B-mod Electronic Unload Controls Parts List P1/PD B-mod Service Information**

<b>B-Mod Unload Control Assembly Part Numbers</b>				
<b>Item No</b>	<b>Qty</b>	<b>C0* Part No</b>	<b>L0* Part No</b>	<b>Description</b>
1	5	Seal kit only	Seal kit only	Teflon O-ring - ARP 012 (Included with #3)
2	2	325-36002-0	325-36002-0	Locator Pin - M3x10 (1 pc with #3)
3	1	S2E-20325-5	S2E-20325-5	Adapter Block Assembly
4	4	Seal kit only	Seal kit only	Teflon O-ring - ARP 011
5	1	108X4V	108X4V	Boss plug & O-ring
6*	1	**	226X56	Load Sense Isolation Set screw - M6x6
7	1	Available in kit only	Available in kit only	Control Housing
8	1	108X4V	**	Load Sense port plug - SAE #4
9	1	**	492-15528-0	Load Sense port adapter fitting (Metric) - SAE #4 to M12x1
		**	492-15527-0	Load Sense adapter fitting (BSPP) - SAE #4 to "1/4 BSPP
10	4	361-07313-8	361-07313-8	Socket head cap Screws - M5x75
11	1	Available in kit only	Available in kit only	Pmax spool
12	1	Available in kit only	Available in kit only	Pmax inner spring guide
13	1	Available in kit only	Available in kit only	Pmax outer spring
14	1	Available in kit only	Available in kit only	Pmax inner spring
15	1	Available in kit only	Available in kit only	Pmax outer spring guide
16	1	Seal kit only	Seal kit only	Pmax outer spring guide O-ring - ARP 009
17	1	Seal kit only	Seal kit only	Pmax plug O-ring - ARP 912
18	1	Available in kit only	Available in kit only	Pmax cap
19	2	311-50018-0	311-50018-0	Adjustment screw - M6x25
20	2	340-00063-0	340-00063-0	Adjustment lock nut - M6
21	1	Available in kit only	Available in kit only	Differential spool
22	1	Available in kit only	Available in kit only	Differential spring inner guide
23	1	Available in kit only	Available in kit only	Differential spring
24	1	Available in kit only	Available in kit only	Differential spring outer guide
25	1	Seal kit only	Seal kit only	O-ring - ARP 009
26	1	Seal kit only	Seal kit only	Back-up ring - ARP 009
27	1	Seal kit only	Seal kit only	Differential plug O-ring - ARP 906
28	1	Available in kit only	Available in kit only	Differential cap
29	1	517-00172-5	517-00172-5	Cartridge valve body
30	1	517-00186-5	517-00186-5	Unload 12VDC cartridge valve coil
	1	517-00174-5	517-00174-5	Unload 24VDC cartridge valve coil

\*Install this plug to make L0\* control

<b>B-Mod Unload Control Kits</b>	
<b>Seal Kit</b>	S2E-20825-5K
<b>C0* Parts Kit*</b>	S2E-18907-5
<b>L0* Parts Kit*</b>	S2E-19388-5
<b>L03 Tested Assembly Kit**</b>	S2E-20209-5T

\*Includes items 2, 5-8, & 11-28

\*\*Does not include adapter block assembly





Item	Torque
4	5 ft-lbs
5	15 ft-lbs
9	50 in-lbs
10	35 in-lbs
11	35 in-lbs
12	35 in-lbs
13	35 in-lbs
15	50 in-lbs
16	35 in-lbs

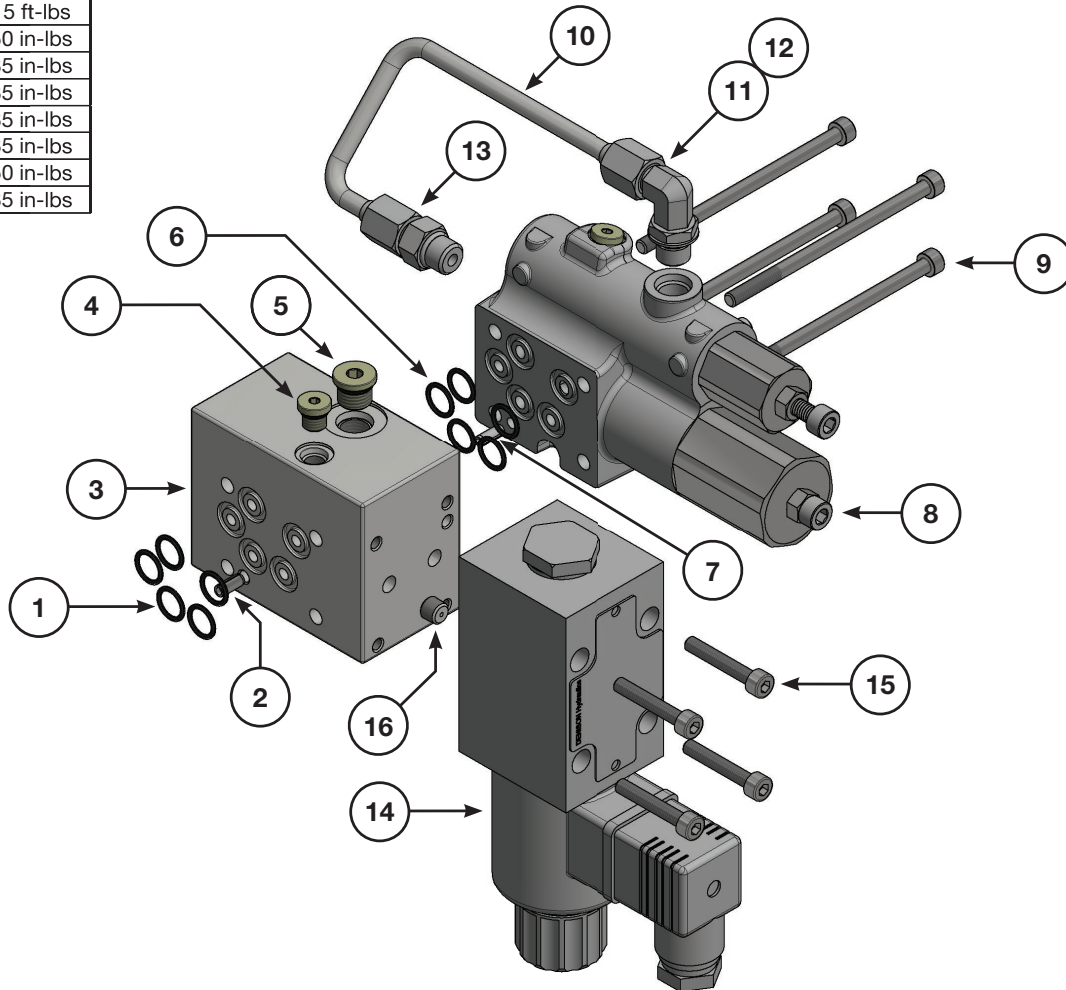

Item	Qty	Part Number	Description
1	5	Seal Kit Only	ARP-012 Teflon O-rings (included in #3)
2	1	325-36001-0	Locating Pin (included in #3)
3	1	S5E-10025-5	Adapter Block
4	1	108X2V	SAE -2 Hex Plug & o-ring (included in #3)
5	1	108X4V	SAE -4 Hex Plug & o-ring (included in #3)
6	5	Seal Kit Only	ARP-012 Teflon O-rings (included in #8)
7	1	325-36001-0	Locating Pin (included in #8)
8	1	See Page 17	AM Compensator
9	4	210X115	M5x90 SHCS
10	1	S5E-10024-0	AN/AE/AF Tubing
11	1	494-15016-0	Elbow Fitting - #4 C5X-S
12	1	Seal Kit Only	Elbow Fitting FKM o-ring
13	1	Seal Kit Only	Fitting with FKM o-ring
14	1	RE06M35W2N1KWYG087	AE Valve with o-rings
		S26-58322-H	AF Valve with o-rings
15	4	361-07275-0	M5x30 SHCS
16	1	035-49171-0	0.06" orifice 1/16PT

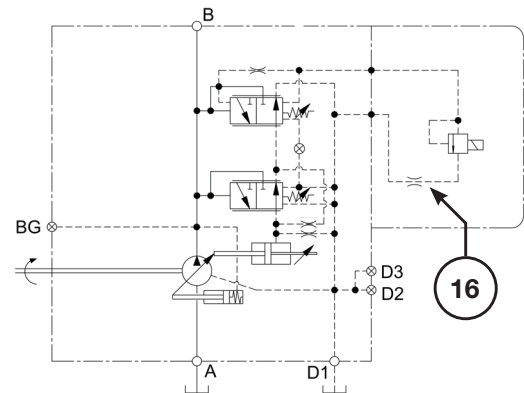

**AG/AH B-mod Controls**

**Medium Pressure Axial Piston Pumps  
P1/PD B-mod Service Information**

Item	Torque
4	50 in-lbs
6	50 in-lbs
7	5 ft-lbs
8	11 ft-lbs
10	50 in-lbs

Part Number	Description
AG7 CW	S2E-19225-5T
AG7 CCW	S2E-19227-5T
AH7 CW	Contact Factory
AH7 CCW	Contact Factory

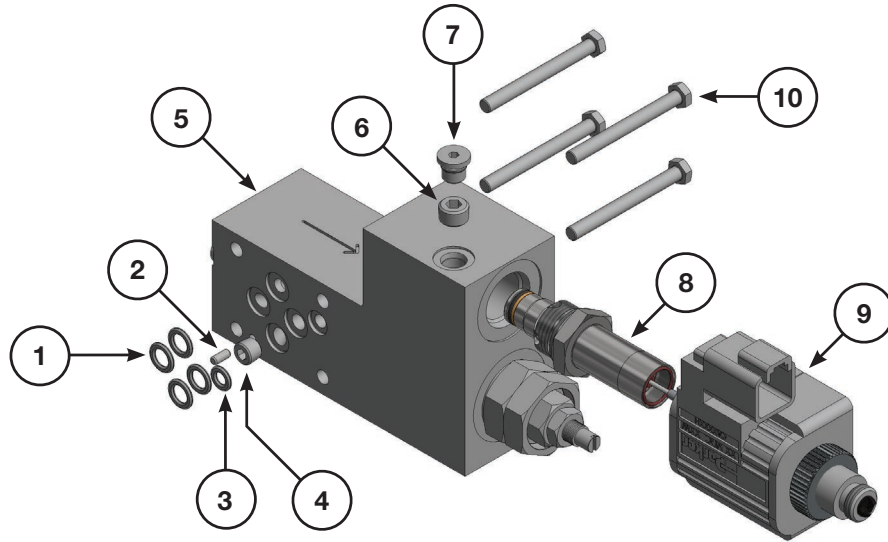

Item	Qty	Part Number	Description
1	4	Seal Kit Only	ARP-011 Teflon o-ring
2	1	325-36002-0	Roll pin (included in item #5)
3	1	Seal Kit Only	O-ring
4	1	03E-95443-0	M5x6 set screw 1.0mm orifice
		03E-95230-0	M5x6 set screw 0.6mm orifice (used in AG7 CCW)
5	1	S2E-19074-5T	CW Control Assembly
		S2E-19159-5T	CCW Control Assembly
6	1	03E-95443-0	M5x6 screw 1.0mm orifice (included in item #5)
7	1	108X2V	SAE -2 Hex plug & o-ring (included in item #5)
8	1	517-00175-5	AP02 Cartridge Valve
		517-00174-5	AG 24V, 28W Solenoid
		517-00186-5	AH 12V, 28W Solenoid
10	4	363-10025-0	M5x50 SHCS

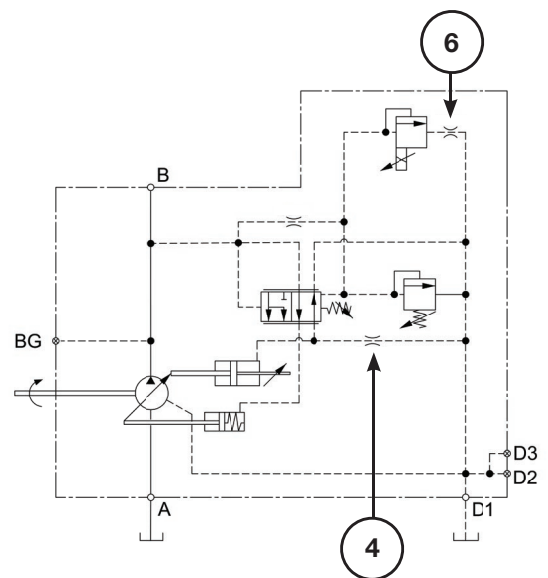

Item	Torque
1	50 in-lbs
10	15 ft-lbs
26	35 in-lbs

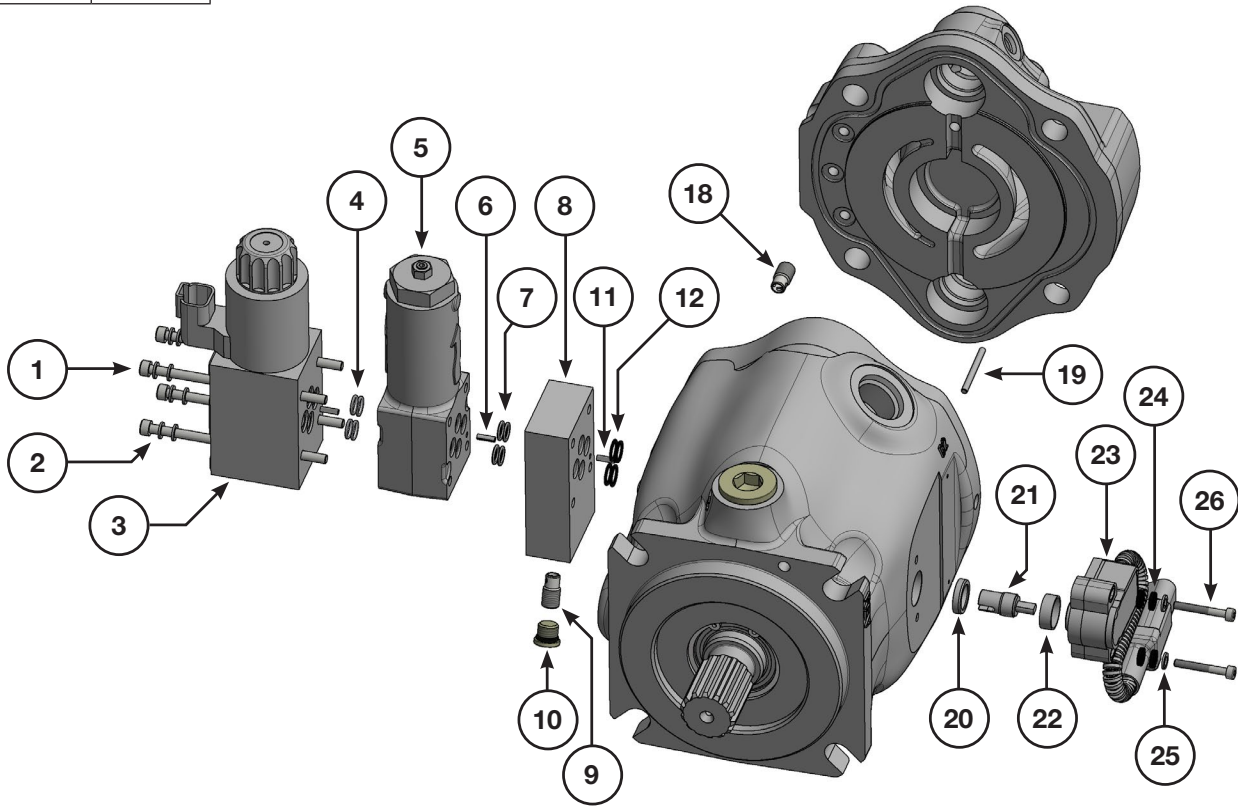

\*CW Rotation Shown

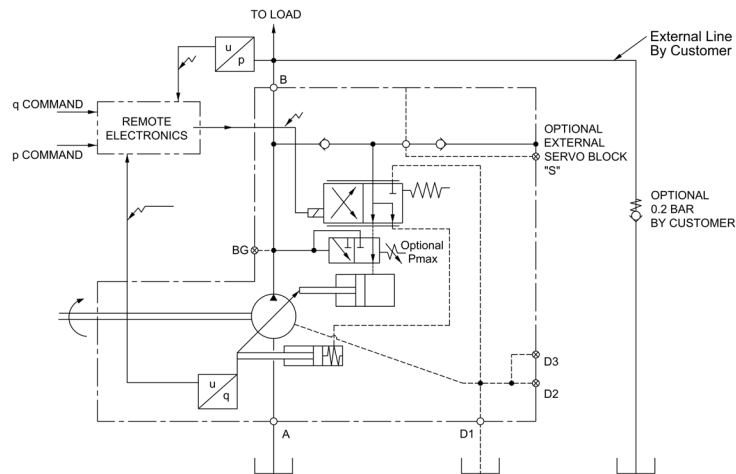

"S" Control Schematic

Item	Qty	Part Number	Description
1	4	210X105	M5x35 SHCS (Control options P & T)
		210X110	M5x60 SHCS (Control options P & T overcenter)
		361-07313-8	M5x75 SHCS (Control options S & U)
		361-07360-8	M5x100 SHCS (Control options S & U overcenter)
2	8	350-10167-0	Lockwasher
3	1	517-00227-5	D1FB 12V Valve (CW Control options P & S)
		517-00220-5	D1FB 12V Valve (CCW Control options P & S)
		517-00226-5	D1FB 12V Valve (CW Control options T & U)
		517-00219-5	D1FB 12V Valve (CCW Control options T & U)
		517-00225-5	D1FB 24V Valve (CW Control options P & S)
		517-00222-5	D1FB 24V Valve (CCW Control options P & S)
		517-00224-5	D1FB 24V Valve (CW Control options T & U)
517-00223-5	D1FB 24V Valve (CCW Control options T & U)		
4	4	Seal Kit Only	ARP-012 FKM o-rings (included with #3)
5	1	S2E-19173-5	Pressure Compensator (CW)
		S2E-19174-5	Pressure Compensator (CCW)
6	1	325-36002-0	Locating Pin (included with #5)
7	4	Seal Kit Only	ARP-011 Teflon o-rings
8	1	S2E-19182-5	Overcenter external servo block
9	1	S13-40266-0	Check valve (included with #8)
10	1	108X4V	SAE -4 Hex plug with o-ring (included with #8)
11	1	325-36002-0	Locating Pin (included with #8)
12	4	Seal Kit Only	ARP-011 Teflon o-rings (included with #8)
18	1	S13-40266-0	Check valve
19	1	03E-94859-0	Cam sensor pin (18, 45-140cc)
		03E-95953-0	Cam sensor pin (28cc)
20	1	Seal Kit Only	Cam sensor seal
21	1	03E-95201-0	Cam sensor shaft connector (18 & 45-85cc)
		03E-95545-0	Cam sensor shaft connector (28cc)
		03E-95205-0	Cam sensor shaft connector (100-140cc)
22	1	03E-95249-0	Cam sensor spacer
23	1	788-80020-0	Cam sensor with Deutsch connector
24	4	350-10170-0	M4 Washer
25	2	350-10167-0	Lock washer
26	2	210X73	M4x30 SHCS

**Parts Kits**

Rotating Group Kits	018	028	045	060	075	085	100	140
P1 CW	S2E-18710-0K	S2E-19119-0K	S2E-19067-0K	S2E-18698-0K	S2E-18032-0K	S5E-10755-0K	S2E-18485-0K	S2E-18489-0K
P1 CW with ripple chamber	S2E-19205-0K	S2E-19209-0K	S2E-19235-0K	**	**	**	**	**
P1 CCW	S2E-18711-0K	S2E-19120-0K	S2E-19068-0K	S2E-18699-0K	S2E-18033-0K	S5E-10756-0K	S2E-18486-0K	S2E-18490-0K
P1 CCW with ripple chamber	S2E-19206-0K	S2E-19210-0K	S2E-19236-0K	**	**	**	**	**
PD CW	S2E-18712-0K	S2E-19121-0K	S2E-19069-0K	S2E-18700-0K	S2E-18483-0K	S5E-10757-0K	S2E-18487-0K	S2E-18491-0K
PD CW with ripple chamber	S2E-19207-0K	S2E-19211-0K	S2E-19126-0K	**	**	**	**	**
PD CCW	S2E-18713-0K	S2E-19122-0K	S2E-19070-0K	S2E-18701-0K	S2E-18484-0K	S5E-10758-0K	S2E-18488-0K	S2E-18492-0K
PD CCW with ripple chamber	S2E-19208-0K	S2E-19212-0K	S2E-19127-0K	**	**	**	**	**

Rotating Group Kit includes barrel, spring, pins, washer, pistons, retainer, port plate, and cam bearings.  
Ripple chamber is only for sided ported configuration

B-mod Seal Kits	018	028	045	060	075/085	100	140
	S2E-20278-5K	S2E-20279-5K	S2E-20280-5K	S2E-20281-5K	S2E-20282-5K	S2E-20283-5K	S2E-20284-5K

Note: Seal kits contain all the seals required for any pump configuration including controls.

**B-mod Control Conversion Kits and Contents**

Kit #1 S2E-20463-5K		Kit #2 S2E-20464-0K		Kit #3 S2E-20465-5K	
Item	Description	Item	Description	Item	Description
21	Differential inner spring guide	2	M5 x 6 set screw with 0.8mm orifice	2	M5 x 6 set screw
22	Differential inner spring	16	M6 x 6 set screw	16	M5 x 6 set screw
23	Differential outer spring	20	AM remote differential spool	17	M4 x 5 set screw
24	Differential outer spring guide			18	Boss plug & O-ring - SAE
25	Differential inner spring guide O-ring			18	Boss plug & O-ring - Metric
26	Differential inner spring guide O-ring			18	Boss plug & O-ring - BSPP
27	Differential main O-ring			19	Boss plug & O-ring
28	Differential outer plug				
29	Differential adjustment lock nut				
30	Differential adjustment screw				

Control Adapter Block Assemblies	
B-mod control on A-mod CW Pump	S2E-20301-5
B-mod control on A-mod CCW Pump	S2E-20302-5
A-mod control on B-mod Pump (CW or CCW)	S2E-20325-5





**Compensator Disassembly  
(C, L & AM B-mod control options)**

**NOTES:**

Access plugs on end of compensator spool bores are hardened plugs. Do not interchange with other plugs in the control.

For rotation change, the complete compensator assembly will need to be replaced.

The Pmax spool and inner spring are NOT interchangeable with the load sense or remote differential spools and springs.

The differential compensator spool and springs are not interchangeable with the main pressure compensator spool and inner spring. Also, the “L” differential spool is not interchangeable with the “AM” differential spool.

**Compensator Disassembly:**

1. Measure and record the extension of the two (only one for “C” control) pressure adjusting screws.
2. Carefully remove the main compensator (Pmax) spring cap (#9) with outer spring guide (#6). For “L” and “AM” controls, the Pmax spring cap is the larger of the two caps. Remove the two springs (#4 & 5). Remove the inner spring guide (#3) and the Pmax spool (#1) from the compensator housing.
3. For the “L” and “AM” controls, carefully remove the differential compensator spring cap (#28) with the outer spring guide (#24). The load sense spring cap is the smaller of the two caps, and the one closer to the top of the controller body. Remove the inner spring guide (#21) and differential compensator spool (#20) from the housing.
4. To disassemble the Pmax cap (#9) and outer spring guide (#6) assembly, thread a long M6 screw through the hole of the Pmax cap to push the outer spring guide out of the cap.
5. To disassemble the differential cap (#28) and outer spring guide (#24) assembly, thread a long M6 screw through the hole of the differential cap to push the outer spring guide out of the cap.
6. Remove all O-ring boss access plugs (#13 & 18).
7. Remove all internal set screws and plugs (#2, 15, & 16).

**Compensator Inspection**

**NOTE:** The compensator is supplied as an assembly. Some individual parts may only be available in kits. See the controls section of this manual for details.

1. Inspect the main compensator (Pmax) spool (#1) and the differential spool (#20) for scratches, damage, or contamination particles.
2. Inspect the springs for proper free extension length (see chart).
3. Inspect the spool bores for scratches, damage, or contamination. Apply a light oil film on the spool(s) and check their fit in the appropriate bore. The spool should fit snugly in the bore and not have any radial play.
4. Inspect orifices for any contamination particles that may be blocking the orifice.

Item No	Component Description	Free Length [mm]	Tolerance Ref. ± [mm]
4	Pmax Inner Spring	28.85	0.66
5	Pmax Outer Spring	35	0.66
22	Differential Inner Spring	14.9	0.66
23	Differential Outer Spring	21	0.66

Reference item numbers on page 13-16.

**Table 1 - P1/PD B-Mod C, L, & AM Compensator Free Spring Length**



**Compensator Assembly**

Carefully clean and dry all parts prior to assembly. Use caution to ensure that spools and other parts are not damaged during the cleaning process. Use clean oil to lubricate seals and spools for easier assembly.

1. Remove and discard all O-rings. Install new O-rings on SAE boss plugs (#13), and install SAE boss plugs (#13) into their respective cavities.
2. Apply a light film of oil to the main compensator (Pmax) spool outer spring guide O-ring (#7), and install it on the Pmax spool outer spring guide (#6).
3. Apply a light oil film to the Pmax outer cap O-ring (#8), and install it on the Pmax outer cap (#9).
4. Apply petroleum jelly to the Pmax outer spring guide (#6) and push it into Pmax outer cap (#9).  
**NOTE:** Make sure the orientation of the guide matches the orientation in the control assembly exploded view section.
5. If possible, turn the compensator housing so that the spool bores face upward. Install set screw (#2) and Pmax spool (#1). Next, place Pmax inner spring guide (#3) inside the Pmax spool bore on top of the Pmax spool (#1). Make sure the orientation of the guide matches the orientation in the control assembly exploded view section. Place the Pmax outer spring (#5) on top of the inner spring guide (#3) in the spool bore. Place the Pmax inner spring (#4) inside the outer spring (#5) so that it sits on top of the inner spring guide (#3).
6. Thread the Pmax outer cap assembly from steps 2-4 into the Pmax spool bore. As the assembly is threaded in the bore, the outer spring (#5) should seat itself on the outer spring guide (#6).
7. Install the Pmax adjustment screw (#11) and lock nut (#10) into the Pmax outer cap (#9).
8. Install the "X" port set screw/orifice (#16) into the "X" port located on top of the compensator.
9. For "C" compensators install the SAE boss plug (#18) in the "X" port on top of the compensator, and set screw plug (#17) into the control port on the bottom of the compensator. Install boss plug (#19) in the differential spool bore.

**Steps 10-15 apply to the "L" or "AM" compensators.**

10. Apply a light film of oil to the differential outer spring guide O-rings (#25 & 26) and install them on the differential outer spring guide (#24).
11. Apply a light film of oil to the differential cap O-ring (#27) and install it on the differential cap (#28).
12. Apply petroleum jelly to the differential outer spring guide (#24) and push it into the differential cap (#27).  
**NOTE:** Make sure the orientation of the guide matches the orientation in the control assembly exploded view section.
13. With compensator housing upright, if possible, so that the bore faces upward, insert the differential spool (#20) into the spool bore. Next, place the differential inner spring guide (#21) on top of the differential spool (#20) inside the spool bore. Make sure the orientation of the guide matches the orientation in the control assembly exploded view section. Then place the differential outer spring (#23) on top of the differential inner spring guide (#21). Then place the differential inner spring (#22) inside the differential outer spring (#22) so that it sits on the differential inner spring guide (#21).
14. Thread the differential cap assembly from step 12 into the differential spool bore. As the assembly is threaded in the bore, the outer spring (#23) should seat itself on the outer spring guide (#24).
15. Install the differential adjustment screw (#30) and lock nut (#29) into the differential outer cap (#28).
16. Install the five O-rings (#14) on compensator ports on the compensator.
17. Using bolts (#12), bolt down compensator assembly onto pump housing. Make sure locating pin (#15) is properly aligned to locating pin hole on the compensator mounting pad on the pump housing.

### Pump Disassembly Notes

- A. Pump disassembly for inspection should be limited to the following cases:
  - a.) Malfunction or oil leakage resulting from damage or wear and tear.
  - b.) Troubleshooting steps/actions listed towards the end of the manual do not solve the problem.
- B. For rotation change or shaft conversion, disassembly should be done only as far as necessary to complete the conversion.
- C. Disassembly and reassembly should be performed in a clean environment. After disassembly, the internal parts should be coated with a film of clean oil and protected from dirt and moisture. Care must be taken to avoid dropping, damaging, or contaminating the machined parts and control valve.
- D. It is usually not necessary to replace spring (20) fitted in cylinder barrel. Do not replace the spring unless absolutely necessary.

**CAUTION:** Spring assemblies in the pump are normally set under high compression and bodily injury may occur if caution is not taken during disassembly.

### Pump Disassembly Procedure

1. Identify the pump from the information on the data tag. See Figure 1.
  2. Drain fluid from housing. Fluid drained from pump should be disposed of properly.
  3. Mount pump in fixture to prevent movement while removing the main housing bolts (#1).
  4. Remove the four bolts holding the compensator assembly to the pump housing. Additional fluid may drain out of the passages when the compensator is removed. For compensator disassembly instructions, see Compensator Disassembly Procedures section.
  5. Remove the four bolts (#1) attaching the port block to the main housing.
  6. Carefully remove the port block (#3) assembly. Except for the 18 & 28cc pump, the control piston guide (#14) and bias guide (#11) are threaded with Loctite into the block (#3). Use caution to avoid dropping the port plate (#9). Note the location of the bias spring (#13) and piston (#12) assembly and the control piston (#15) assembly. The control piston (#15), bias piston (#12), and bias spring (#13) may remain in the pump when the port block is removed. Remove these items from inside the pump if they remained in the pump when the port block was removed. Remove and discard the white Teflon O-rings (#8) on the port block. These seals should be replaced every time the pump is disassembled.
- NOTE:** For rotation change, do not disassemble further. See Rotation Change Procedure.
7. For the 60-140cc pumps, remove the tapered roller bearing cone (#18) and shims (#17).



Figure 1 Pump Data Tag

**Pump Disassembly Procedure  
(Continued)**

8. Position the pump horizontally and remove the rotating group. Avoid separating the pistons (#27) from the barrel (#23) if possible. This will assist in identifying damage between an individual piston and barrel bore during component inspection.

**NOTE:** If completing a seal change or complete overhaul on a 45cc pump or larger, turn the housing over and remove the seal retainer snap ring (#40) and shaft seal (#39) from the housing before moving to step 9.

**NOTE:** For shaft change only on 45cc pumps or larger, no further disassembly is required. Proceed to Step 7 of the assembly procedure.

9. Remove the cam (#29) from the housing by tilting it and carefully extracting it from the pump housing. See Figure 2.

Large Pocket

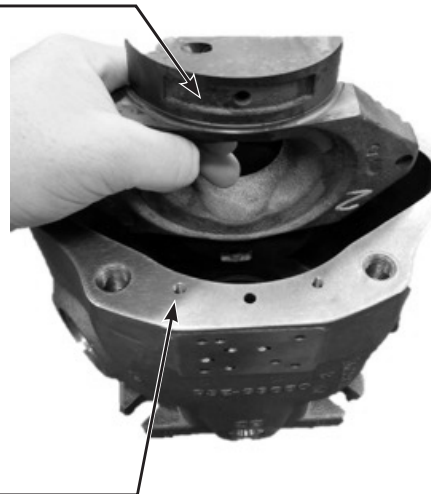

Pressure Control  
Side of Pump

**Figure 2**

10. For sizes 60-140cc remove the front tapered roller bearing cone (#32). If there is excessive wear or damage, remove the tapered roller bearing cup (#33) from the bottom of the housing.
11. Remove the cam bearing screws (#30) and two cam bearings (#31).
12. Remove the housing snap ring (#43) and shaft bearing assembly (#32).
13. If completing a seal change or complete overhaul, turn the housing over and remove the seal retainer snap ring (#40) and shaft seal (#39) from the housing. For a 45cc pump or larger, this step was already completed as part of step 8.
14. If there is excessive wear on the port block bearing (#18) (bushing for sizes 18, 28 & 45), remove the bearing or bushing from the port block (#3).

**Pump Inspection Procedures**

1. Carefully clean and dry all parts prior to inspection.
2. Examine piston diameters for scratches or gouges. If any piston is severely damaged, note which piston bore it came out of. Extra attention should be given to that bore in Step 4.
3. Check end play of piston shoe assembly. Check bottom surface of the shoes for damage or excessive scratching. The shoe surface should be square and flat. Measure the depth of the pocket of the shoe. Shoes may be lapped as a set if the pocket depth is within the allowable limits. Confirm pocket depth after lapping to ensure it is still within the limits.
4. Examine the bores in the cylinder barrel (#23) for scratches or gouges. If there are any scratches or gouges, the barrel needs to be replaced. Examine the barrel running face for scratches or gouges.
5. Examine the port plate (#9) for scratches, gouges, pitting, material removal or discoloration. It can be lapped lightly if the face is only lightly scratched; otherwise, it should be replaced. Refer to the chart for lapping limits.
6. Examine the retainer plate (#26) in the area of contact with the piston shoes. Any marks beyond light polishing indicate that replacement is necessary. Check the surface of the spherical area of the retainer plate and the spherical guide washer (#25). Inspect the back surface of the spherical guide washer where the load pins (#24) make contact. If there are excessive or uneven indentations, the spherical guide washer (#24) needs replaced.
7. Examine the top and bottom surfaces of the cam (#29). If scratches or gouges appear to penetrate the surface treatment, then the cam (#29) should be replaced.
8. Inspect the cam bearings (#31). They cannot be reworked and should be replaced if worn through the Teflon surface coating.
9. Both the bias piston (#12) and the control piston (#15) should move freely in their respective guides. The pistons and bores should be free of scratches or gouges. If not, they need to be replaced.
10. The seal area of the drive shaft (#28) should be smooth and be free of marks from seal wear. For the larger pumps with tapered roller bearings, the bearing surfaces should not have any indication of the bearing cone (#32) spinning on the shaft. Keyed shafts should be inspected for signs of brinelling and damage to the key area. If replacing the keyed shaft, then the key should be replaced as well. Spline shafts may have a contact wear pattern, but should not show excessive wear on the spline area.
11. Spin the shaft bearing (#32). It should not have any signs of roller spalling, brinelling, or discoloration. It should rotate freely without binding or rough feel.



Item No	9	13	21	23	27
<b>Component</b>	Port Plate	Bias spring	Barrel hold down spring	Barrel Part Number	Piston and shoe assembly Sold in sets only
<b>018</b>	2.97mm	03E-94430-0 78.3 mm	787635 41.4 mm	03E-94717-0	789519 Max end play 0.10 mm Min shoe flange Thickness 2.97 mm
<b>028</b>	3.98mm	03E-94393-0 87.5 mm	03E-94387-0 39.5 mm	03E-94375-0	S2E-18415-0 Max end play 0.07 mm Min shoe flange Thickness 3.98 mm
<b>045</b>	4.98mm	03E-94356-0 116.4 mm	03E-94350-0 48.3 mm	03E-94338-0	S2E-184130-0 Max end play 0.10 mm Min shoe flange Thickness 4.98 mm
<b>060</b>	4.98mm	112.0mm	58.5 mm	03E-94036-0	03E-94036-0 Max end play 0.004 in (0.10 mm) Min Shoe Flange Thickness 0.233 in (5.91 mm)
<b>075/085</b>	5.98mm	03E-93151-0 5.57 in (141.5 mm)	03E-93145-0 2.50 in (63.7 mm)	03E-93129-0	S2E-17003-0 Max End Play 0.004 in (0.10 mm) Min Shoe Flange Thickness 0.233 in (5.91 mm)
<b>100</b>	6.48mm	03E-93801-0 6.87 in (174.6 mm)	03E-93795-0 2.84 in (72.2 mm)	03E-93783-0	S2E-17912-0 Max End Play 0.005 in (0.13 mm) Min Shoe Flange Thickness 0.252 in (6.41 mm)
<b>140</b>	6.48mm	03E-93963-0 8.36 in (212.3 mm)	03E-93959-0 2.70 in (68.6 mm)	03E-93242-0	S2E-17323-0 Max end play 0.005 in (0.13 mm) Min shoe flange Thickness 0.252 in (6.41 mm)
<b>Tolerances</b>	Minimum allowable thickness after lapping  0.8 mm minimum allowable surface finish	Free Height: ± 0.020 in (± 0.51mm)	Free Height: +/- 0.2mm	Max material to be removed by lapping is 0.0002 in (0.0051mm)	End play between piston and shoe should not exceed values shown. Total material allowed to be removed from shoe face when lapping is 0.003 in (0.076mm)

Table 2 - Component Rework Information

### Pump Assembly Procedures

Any seals removed during disassembly, including the shaft seal, should be replaced. For major overhauls, all plugs should be removed and their O-rings replaced.

Assembly should be performed in a clean work environment.

Do not use bearing grease during installation. Grease does not dissolve in hydraulic oil and may plug orifices or filters in the system. Clean petroleum jelly is preferred to lubricate O-rings and seals and to adhere parts for assembly.

**NOTE:** For fluids other than petroleum based hydraulic oil, ensure that the petroleum jelly is compatible with the fluid. If not compatible, another product should be used instead.

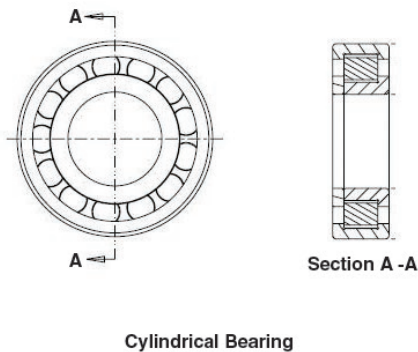

1. Make sure new parts are clean, or if re-using parts, make sure they are thoroughly cleaned.
2. Inspect all bearing surfaces and seal areas to ensure that they are free from nicks, dings, scratches, or rust.
3. For the 45cc pump, skip step 3. For the 18 and 28cc pumps, turn the housing over. Use installation tool T1 and press the shaft seal (#39) in the seal bore. Install the snap ring (#40) into the groove in the housing seal bore.
4. Install the cylindrical shaft bearing (#32) onto the pump shaft (#28). It is a slip fit for the 18 and 28cc pumps. For the 45cc pump, use tool T2 to install the shaft bearing onto the pump shaft.
5. Install the external retaining ring (#42) to secure the bearing in place on the shaft. For the 45cc pump, use tool T3 to install the shaft seal (#39) over the shaft. Tool T3 will help protect the shaft seal from being damaged by the splines during shaft installation. For all three sizes, insert the shaft assembly into the pump housing with the bearing sliding into the bearing diameter in the housing. Be sure not to cut or damage the shaft seal while installing the shaft. For the 28cc pump, tool T3 can be used to protect the shaft seal from damage from the splines of the shaft. For the 18 and 28cc pumps, install the internal retaining ring (#43) into the housing. For the 45cc pump, install the shaft seal snap ring (#40) into the groove in the housing seal bore.
6. If the barrel hold down spring (#21) was removed during the disassembly process, place the barrel (#23) on fixture with piston bores down. Install the back-up washer (#22), hold down spring (#21), and second back-up washer (#22). On the 45cc pump and larger, there is only one back-up washer (#22). Compress the spring in a press and install the snap ring (#20). Next, rotate the barrel assembly so that the piston bores face up. Slide tool T6 up through the center of the barrel from the bottom side. Place the three barrel pins (#24) into the three slots in the barrel spline as shown in Figure 3. In lieu of tool T6, petroleum jelly can be used to hold the pins in place while installing the remaining parts.

**CAUTION:** Make sure the snap ring (#20) is properly seated in its groove prior to removing the barrel assembly from the press.



Figure 3

**Pump Assembly Procedures  
(Continued)**

7. Apply a light oil film into the piston bores of the barrel (#23). Lightly lubricate the spherical surface of the spherical retaining plate washer (#25). Install the nine pistons (#27) into the bores in the retaining plate (#26). Assemble the spherical retaining plate washer into the retaining plate. While holding the spherical washer against the retaining plate, slide the pistons into the barrel.
8. Install the two port block locating/dowel pins (#17) and the one port plate locating pin (#7) into their respective locations on the port block (#3) face.
9. Install the port block control flow set screw (#6) in the proper location depending on pump rotation. For proper location, see Figure 11 in the rotation change section. The set screw should be installed in the passage on the same side of the port block as the control piston.
10. For the 45cc pump, install unlubricated O-rings (#10) onto the control piston guide (#14) and bias guide (#11). Next, apply Loctite Primer SF 194500 or similar to the control piston guide and bias guide threads and allow it to dry. The primer usually dries in about three minutes. Next, apply Loctite 263 to the guide threads. For CCW rotation, install the bias guide (#11) nearest to the locating pin (#17). See Figure 5A. For CW rotation, install the control piston guide (#14) nearest to the locating pin (#17). See Figure 5B. Torque the guides to 105 ft lbs. For the 18 and 28cc pumps, press the guides into the port block.

**NOTE:** Torquing needs to be done in less than two minutes; otherwise, the Loctite will set too soon and the guides will not be able to be fully torqued.

**045 Picture**

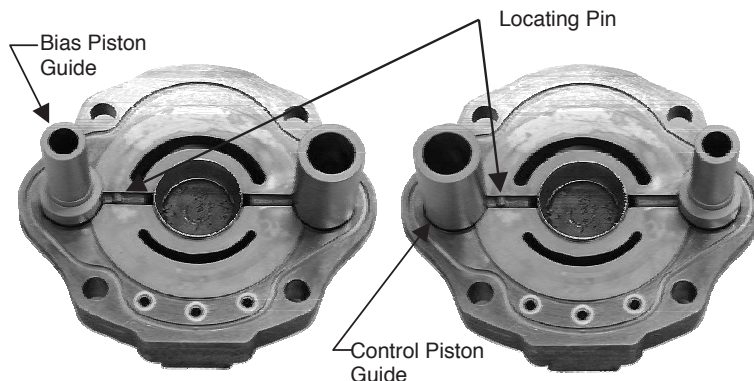
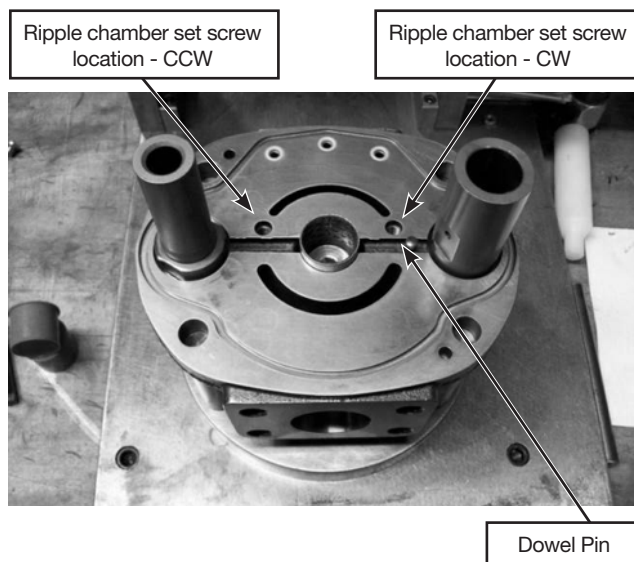

**Figure 5A**  
Port Block with Left  
Hand Configuration

**Figure 5B**  
Port Block with Right  
Hand Configuration

11. Apply a light oil film to the control piston (#15), and install it into the control guide (#14) bore. Apply a light oil film to the bias piston (#12). Install the bias spring (#13) over the bias guide (#11) bore, and then slide the bias piston into the bias guide bore.
12. For side ported non thru drive pumps, install the ripple chamber set screw (#16) and plug (#19) and torque per the torque table values. For CW units, the set screw is installed nearest to the locating pin. For CCW units, the set screw is installed furthest from the locating pin. See Figure 6. Pumps that are end ported or have a thru drive do not have a ripple chamber.

**Pump Assembly Procedures  
(Continued)**



**Figure 6 - Port Block Assembly with Ripple Chamber**

Table 3	
Pump	Housing bolt torque
018	52 ft lbWs (70 Nm)
028	52 ft lbs (70 Nm)
045	63 ft lbs (85 Nm)

13. Install the port block bushing (#18) into the port block face using tool T5.
14. Apply a light layer of petroleum jelly to the back surface of the port plate (#9). Install it on the port block (#3), lining up the slot on the port plate with the port plate locating pin (#7). See Figure 7.

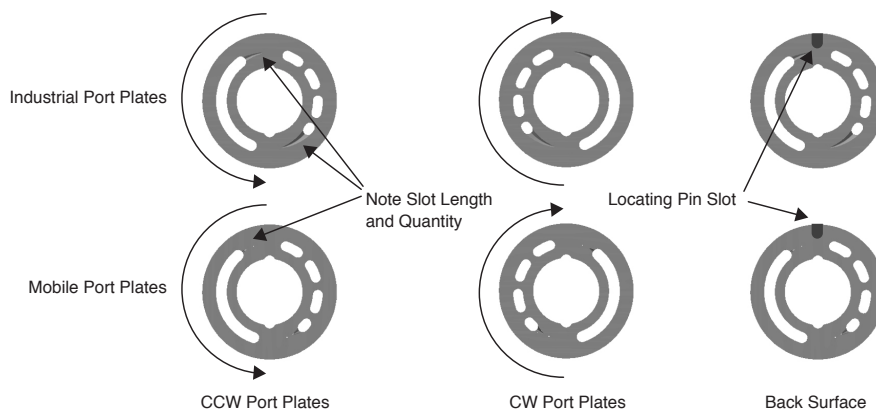

**Figure 7**

15. Install the large O-ring (#4) into the groove on the port block (#3). Install the three Teflon O-rings (#8) on the pressure communication ports on the port block.
16. Install the control flow housing set screw (#34) into the proper passage. For proper location, see Figure 12 in the rotation change section.
17. Place the cam bearings (#31) in the cradle area of the housing. Apply two drops of Loctite 243 (use sparingly) to the cam bearing screw (#30) threads and install the screws to hold the cam bearings in place. Torque the screws per the torque table on page 7.

Pump Assembly Procedures  
(Continued)



Figure 8 - Cam Bearings

**NOTE:** Make sure the Loctite does not get in the orifice hole in the cam bearing screws.

18. Place thin film of clean oil on the cam bearing (#31) surfaces. Install the cam (#29) in the housing. For the 45cc pump, the cam must be tilted to permit entry into the housing. See Figure 2.

**NOTE:** The large pocket on the bottom surface of the cam must be on the same side as the three pressure communication holes on the main housing. Cam assembly is not affected by pump rotation direction.

19. Position the pump horizontally and install the rotating group into the pump housing over the pump shaft (#28) and against the cam (#29) with tool T6 in place in the center of the barrel (#23). Remove tool T6 as the barrel is slid onto the shaft. This ensures all three barrel pins (#24) are held in place as the rotating group is installed on the shaft.
20. Carefully install the assembled port block (#3) on the pump housing. Press the port block to compress the bias spring (#13) and install the four housing bolts (#1). Tighten the bolts in a cross pattern to ensure that the port block does not get cocked on the housing. When the port block is seated on the housing, torque the bolts in a cross pattern per the values in the Table 3.
21. On the 18 & 28cc units, install the M6x6 set screw with orifice (#38) into the BG port in the housing (#35) if it was removed during disassembly.
22. Install any boss plugs (#2, 5, 36 & 37) that were removed during disassembly.
23. Install five O-ring seals and assembled compensator (#41) on the side of the pump housing. Tighten the compensator bolts hand tight, and then torque the bolts per the values in the torque table on page 13.

**Pump Assembly Procedures**

Any seals that were removed during disassembly, including the shaft seal, should be replaced. For major overhauls, all plugs should be removed and their O-rings replaced.

Assembly should be performed in a clean work environment.

Do not use bearing grease during installation. Grease does not dissolve in hydraulic oil and may plug orifices or filters in the system. Clean petroleum jelly is preferred to lubricate O-rings and seals and to adhere parts for assembly.

**NOTE:** For fluids other than petroleum based hydraulic oil, insure that the petroleum jelly is compatible with the fluid. If not compatible, another product should be used instead.

1. Make sure new parts are clean, or if re-using parts, make sure they are thoroughly cleaned.
2. Inspect all bearing surfaces and seal areas to ensure that they are free from nicks, dings, scratches, or rust.
3. Use tool T7 to press the front shaft bearing cup (#33) into the bottom of the housing. Make sure the cup is seated firmly against the bottom of the housing.
4. Turn housing over and use tool T1 to press the shaft seal (#39) into the seal bore of the housing. Install the snap ring (#40) into the groove in the seal bore.
5. Use tool T8 to press the rear shaft bearing cup (#18) into the port block (#3). Insure that the cup is seated firmly against the bottom of the casting. Install the front shaft bearing cone (#32) and shaft (#28) into the housing. Tool T3 can be used to help protect the shaft seal from damage from the splines when installing the shaft. Install the rear shaft bearing cone (#19) on the shaft.
6. Mount the port block (#3) onto the housing (#35) using the four socket head cap screws (#1), and tighten to 20 ft-lbs +/- 1 ft-lb.
7. Position the pump so the shaft end is up and lay a parallel bar on the pump mounting flange pilot. Press down on the shaft and rotate the shaft 3-5 times then measure the height of the shaft end to the parallel bar using dial calipers or a dial indicator. Grasp the shaft and pull it up and rotate the shaft 3-5 times. Measure the height of the shaft end to the parallel bar. See Figure 9. Subtract the larger number from the smaller to get the gap differential. Repeat this step three times, and calculate the average gap differential of the three measurements.

**NOTE:** If the shaft slips or falls, this step must be repeated to get an accurate measurement.

8. Based on the average gap differential, use the shim chart to determine the correct shim (#17) to install in the pump.
9. Verify the correct shim (#17) was selected by rebuilding the pump with the shaft bearings, shaft, and selected shim. Install the shaft bearing cone (#32). Next, insert the shaft (#28) into the housing (#35) through the cone. Place the shim over the shaft, and then install the port block bearing cone (#19) over the shaft. Finally, install the port block (#3) onto the housing and pull on the shaft to check for any shaft end play or excessive movement.
10. Remove the port block (#3) from the housing. Then remove the port block bearing cone (#19) and shim (#17) and continue with the rest of the assembly.



**Pump Assembly Procedures  
(Continued)**

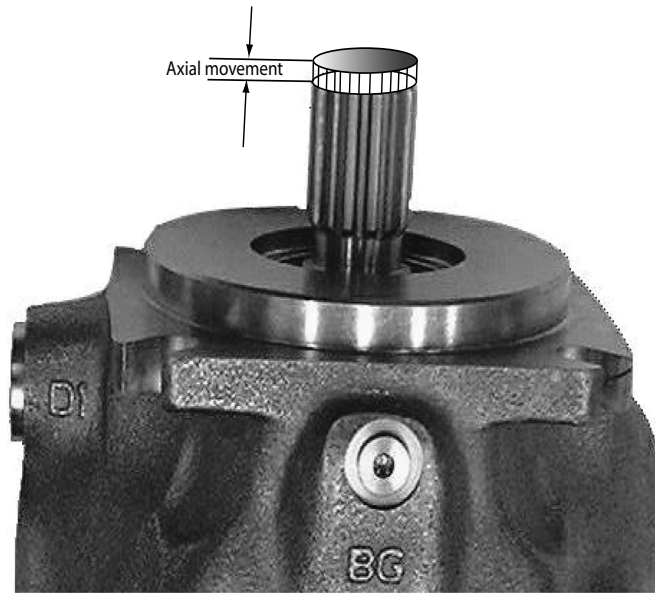

**Figure 9**

Measured Differential		Shim Thickness	Displacement		
Minimum	Maximum		060/075/085	100	140
3.07 mm (.121 in)	3.12 mm (.123 in)	3.04 mm (.1196 in)	03E-95262-0	03E-95268-0	03E-95265-0
3.15 mm (.124 in)	3.22 mm (.126 in)	3.12 mm (.1228 in)	03E-95263-0	03E-95269-0	03E-95266-0
3.23 mm (.127 in)	3.29 mm (.129 in)	3.20 mm (.1259 in)	03E-95264-0	03E-95270-0	03E-95267-0
3.30 mm (.130 in)	3.36 mm (.132in)	3.28 mm (.1291 in)	03E-93180-0	03E-94148-0	03E-93260-0
3.37 mm (.133 in)	3.44 mm (.135 in)	3.36 mm (.1323 in)	03E-93566-0	03E-94149-0	03E-93970-0
3.45 mm (.136 in)	3.51mm (.138 in)	3.44 mm (.1354in)	03E-93567-0	03E-94150-0	03E-93971-0
3.52 mm (.139in)	3.62 mm (.142 in)	3.52 mm (.1386 in)	03E-93568-0	03E-94151-0	03E-93972-0
3.63 mm (.143 in)	3.70 mm (.145 in)	3.60 mm (.1417 in)	03E-93569-0	03E-94152-0	03E-93973-0
3.71 mm (.146 in)	3.77 mm (.148 in)	3.68 mm (.1449 in)	03E-93570-0	03E-94153-0	03E-93974-0
3.78 mm (.149 in)	3.85 mm (.151 in)	3.76 mm (.1480 in)	03E-93571-0	03E-94154-0	03E-93975-0
3.86 mm (.152 in)	3.92 mm (.154 in)	3.84 mm (.1512 in)	03E-93572-0	03E-94155-0	03E-93976-0
3.93 mm (.155 in)	4.00 mm (.157 in)	3.92 mm (.1539 in)	03E-93573-0	03E-94156-0	03E-93977-0
4.01 mm (.158 in)	4.10 mm (.161 in)	4.00 mm (.1575 in)	03E-93574-0	03E-94157-0	03E-93978-0
4.11 mm (.162 in)	4.18 mm (.164 in)	4.08 mm (.1606 in)	03E-93575-0	03E-94158-0	03E-93979-0
4.19 mm (.165 in)	4.25 mm (.167 in)	4.16 mm (.1638 in)	03E-93576-0	03E-93864-0	03E-93980-0
Shim Kits:			S2E-18591-0K	S2E-18640-0K	S2E-18527-0K

**Table 4 - Shim Thickness Selection**

**Pump Assembly Procedures  
(Continued)**

Pump	Control and Bias Guide Torque
060	105 ± 5 ft-lbs (142 ± 6.5 Nm)
075 /085	105 ± 5 ft-lbs (142 ± 6.5 Nm)
100	136 ± 6 ft-lbs (184 ± 8 Nm)
140	170 ± 6 ft-lbs (203 ± 8 Nm)

- If the barrel hold down spring (#21) was removed, place the barrel (#23) on fixture with pin side down and install the back-up washer (#22) and hold down spring. Compress the spring in a press and install the snap ring (#20). Next, rotate the barrel assembly so that the piston bores face up. Place the three barrel pins (#24) into the three slots in the barrel spline as shown in Figure 3. Petroleum jelly can be used to hold the pins in place while installing the remaining parts.

**CAUTION:** Make sure the snap ring (#20) is properly seated in the groove prior to removing the barrel (#23) from the press.

- Apply a light oil film into the piston bores of the barrel (#23). Lightly lubricate the spherical surface of the spherical retaining plate washer (#25). Install the nine piston bores down (#27) into the bores in the retaining plate (#26). Assemble the spherical retaining plate washer into the retaining plate. While holding the spherical washer against the retaining plate, slide the pistons into the barrel.
- Install the port block locating/dowel pin (#7) into the port block (#3) face.
- Install the port block control flow set screw (#6) in the proper location depending on pump rotation. For proper location, see Figure 11 in the rotation change section. The set screw should be installed in the passage on the same side of the port block as the control piston.
- Install unlubricated O-rings (#10) onto the control piston guide (#14) and bias guide (#11). Apply Loctite Primer SF 194500 to the control piston guide and bias guide threads and allow it to dry. This usually take about three minutes. Apply Loctite 263 to the guide threads. For CW rotation, install the control piston guide (#14) nearest to the locating pin. See Figure 10A. For CCW rotation, install the bias guide (#11) nearest to the locating pin (#7). See Figure 10B. Torque the guides per the values specified in the Table 4.

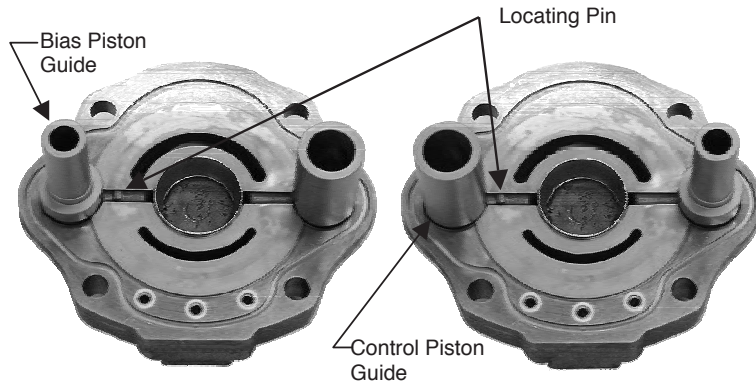

**Figure 10A**  
Port Block with Left  
Hand Configuration

**Figure 10B**  
Port Block with Right  
Hand Configuration

- Apply a light oil film to the control piston (#15), and install it into the control guide (#14) bore. Apply a light oil film to the bias piston (#12). Install the bias spring (#13) over the bias guide (#11) bore, and then slide the bias piston into the bias guide bore.
- Install the control flow housing set screw (#34) into the proper passage. For proper location, see Figure 12 in the rotation change section.
- Apply a light layer of petroleum jelly to the back surface of the port plate (#9) and place it on the port block (#3), lining up the slot on the port plate with the locating pin (#7). See Figure 7.

**Pump Assembly Procedures  
(Continued)**

<b>Pump</b>	<b>Housing Bolt Torque</b>
060	100 ± 4 ft-lbs (135.6 ± 5 Nm)
075 / 085	100 ± 4 ft-lbs (135.6 ± 5 Nm)
100	170 ± 5 ft-lbs (229 ± 7 Nm)
140	205 ± 5 ft-lbs (278 ± 7 Nm)

19. Install the large O-ring (#4) into the groove on the port block (#3). Install the three Teflon O-rings (#8) on the pressure communication ports on the port block.
20. Place the cam bearings (#31) in the cradle area of the housing. The chamfer on the back of the bearing must face the outer wall of the housing. Use Loctite Primer Grade “T” or other suitable primer on the cam bearing screws (#30) and mating housing threads. Allow the primer to dry. This usually take ten minutes. Apply Loctite 243 (use sparingly) to the cam bearing screw threads and install the screws to hold the cam bearings in place. Torque the screws per torque table values on page 9.
21. Place thin film of clean oil on the cam bearing (#31) surfaces. Install the cam (#29) in the housing. The cam must be tilted to permit entry into the housing. See Figure 2.

**NOTE:** The large pocket on the bottom surface of the cam must be on the same side as the three pressure communication holes on the main housing. Cam assembly is not affected by pump rotation direction.

22. Position the pump horizontally and install the rotating group into the pump housing over the pump shaft (#28) and against the cam (#29).
23. Place the bearing shim (#17) and port block bearing cone (#19) on around the drive shaft (#28).
24. Carefully install the assembled port block (#3) on the pump housing. Press the port block to compress the bias spring (#13) and install the four housing bolts (#1). Tighten the bolts in a cross pattern to ensure that the port block does not get cocked on the housing. When the port block is seated on the housing, torque the bolts in a cross pattern per the values in Table 6.
25. Install any boss plugs (#2, 5, 16, 36 & 37) that were removed during disassembly.
26. Install the five O-ring seals and assembled compensator (#41) on the side of the pump housing. Tighten the compensator bolts hand tight, and then torque bolts per torque table on page 13.

**Assembly Tools**

**T1 Seal Installation Tool**

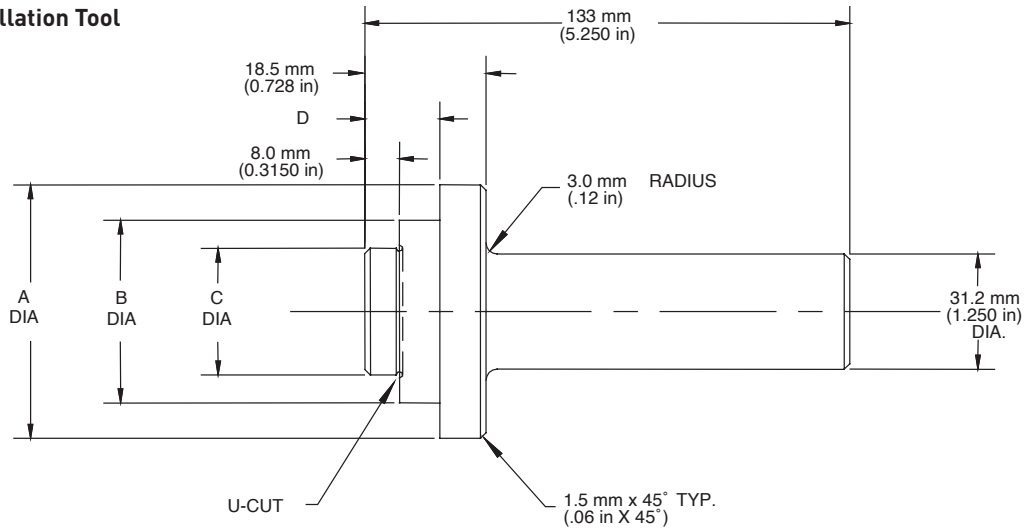

Pump Model	Part No	A	B	C	D
018		2.250 in	1.62 in	1.18 in	0.406 in
028		2.250 in	2.00 in	1.375 in	0.447 in
060 / 075 / 085	213-0-004194	2.750 in (69.9 mm)	1.980 in (50.3 mm)	1.375 in (34.9 mm)	0.800 in (20.3 mm)
100	213-0-004208	2.50 in (63.5 mm)	2.230 in (56.6 mm)	1.703 in (43.3 mm)	0.550 in (14.0 mm)
140	213-0-004199	3.375 in (85.7 mm)	2.780 in (70.6 mm)	2.10 in (53.4 mm)	0.750 in (19.1 mm)

**T2 Front Bearing Installation Tool (45 only)**

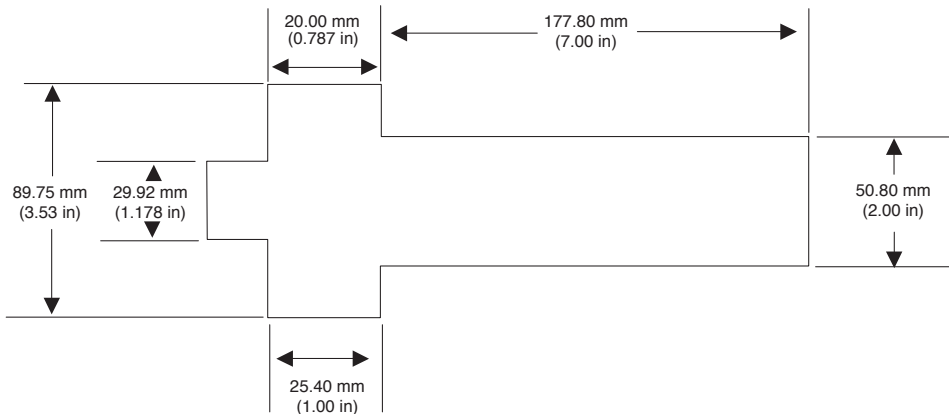

**Assembly Tools**

**T3 Seal Guard**

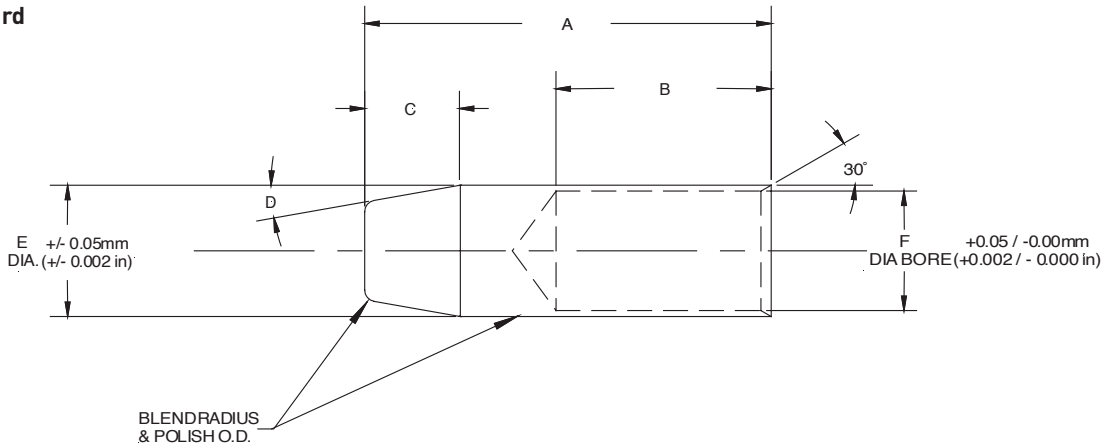

Pump Model	Part Number	A	B	C	D	E	F
018 ("01", "02", "04" Shafts)		3.00 in (76.20 mm)	2.00 in (50.80 mm)	0.75 in (19.05 mm)	15°	1.135 in (28.82 mm)	0.805 in (20.45 mm)
018 ("06" Shaft)		3.00 in (76.20 mm)	2.00 in (50.80 mm)	0.75 in (19.05 mm)	15°	1.135 in (28.82 mm)	0.66 in (16.76 mm)
028 / 045 ("01", "02", "04" Shafts)		3.00 in (76.20 mm)	2.00 in (50.80 mm)	0.75 in (19.05 mm)	15°	1.50 in (38.10 mm)	1.024 in (26.00 mm)
018 / 028 / 045 ("08" Shaft)		3.00 in (76.20 mm)	2.00 in (50.80 mm)	0.75 in (19.05 mm)	15°	1.135 in (28.82 mm)	0.885 in (22.50 mm)
060 / 075 / 085	213-0-004195	4.25 in (108 mm)	2.25 in (57.1 mm)	1.00 in (25.4 mm)	10°	1.373 in (34.90 mm)	0.885 in (31.75 mm)
100 SAE	213-0-004206	4.25 in (108 mm)	2.78 in (70.6 mm)	1.00 in (25.4 mm)	10°	1.703 in (43.26 mm)	1.5 in (38.1 mm)
100 ISO	213-0-004207	4.50 in (114 mm)	3.00 in (76.2 mm)	0.88 in (22.4 mm)	15°	1.703 in (43.26 mm)	1.577 in (40.06 mm)
140 SAE	213-0-004200	4.25 in (108 mm)	2.78 in (70.6 mm)	1.00 in (25.4 mm)	10°	2.088 in (53.04 mm)	1.751 in (44.48 mm)
140 ISO	213-0-004201	4.50 in (114 mm)	3.00 in (76.2 mm)	0.88 in (22.4 mm)	15°	2.088 in (53.04 mm)	1.970 in (50.04 mm)

**T5 Rear Bushing Installation Tool  
(18 thru 45)**

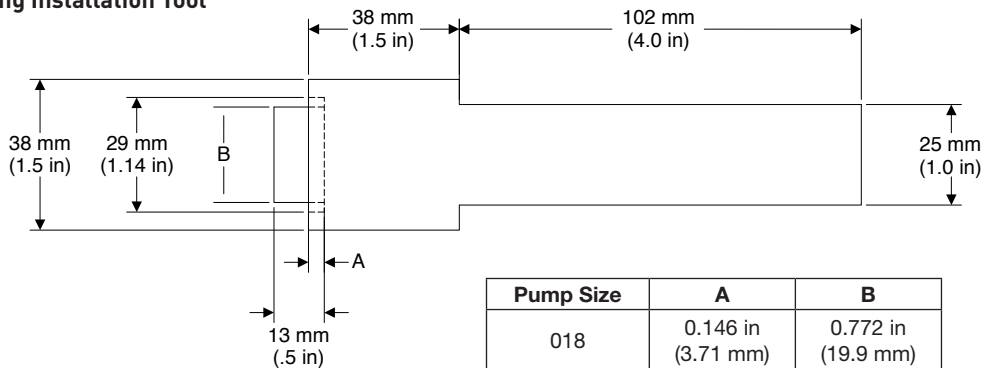

Pump Size	A	B
018	0.146 in (3.71 mm)	0.772 in (19.9 mm)
028	0.157 in (4.00 mm)	0.85 in (21.6 mm)
045	0.157 in (4.00 mm)	0.95 in (24.1 mm)



**T6 Barrel Pin Tool**

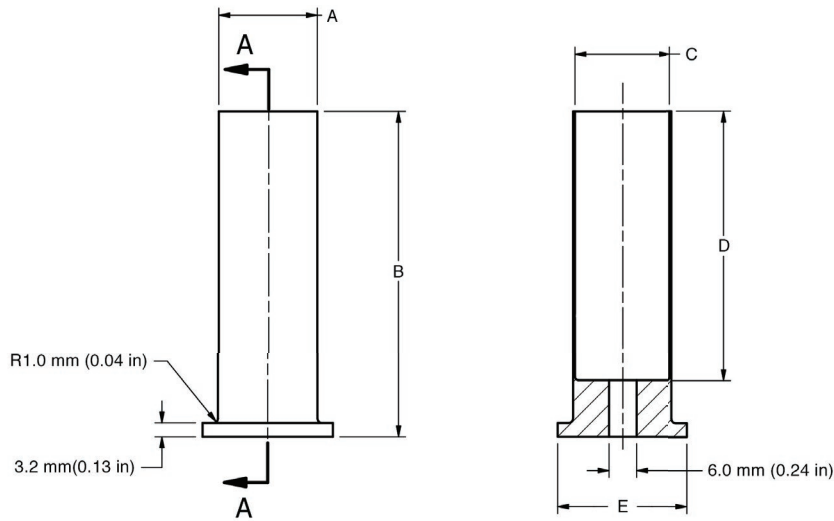

Pump Size	A	B	C	D	E
018	0.795 in (20.2 mm)	2.84 in (72.0 mm)	0.756 in (19.2 mm)	2.32 in (59.0 mm)	1.18 in (30.0 mm)
028	0.902 in (22.9 mm)	2.95 in (75.0 mm)	0.862 in (21.9 mm)	2.44 in (62.0 mm)	1.18 in (30.0 mm)
045	1.059 in (26.9 mm)	3.35 in (85.0 mm)	1.020 in (25.9 mm)	2.84 in (72.0 mm)	1.30 in (33.0 mm)

**T7 Front Bearing Cup Tool (60 thru 140)**

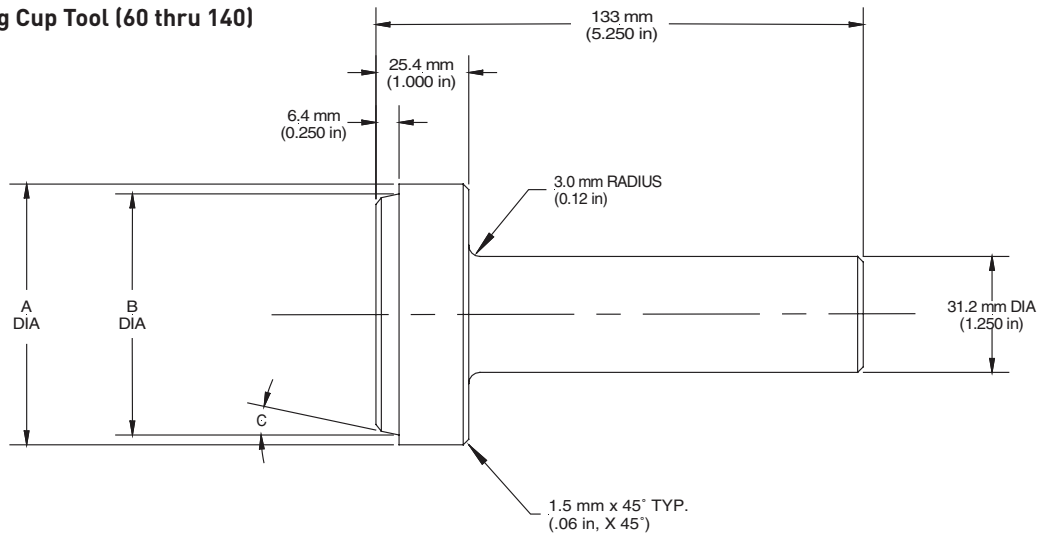

Pump Model	Part No	A	B	C
060 / 075 / 085	213-0-004192	2.812 in (71.4 mm)	2.60 in (66.0 mm)	12°
100	213-0-004204	3.623 in (92.1 mm)	3.390 in (86.1 mm)	15°
140	213-0-004197	3.687 in (93.7 mm)	3.515 in (89.3 mm)	15°



**Assembly Tools**

**T8 Rear Bearing Cup Tool (60 thru 140)**

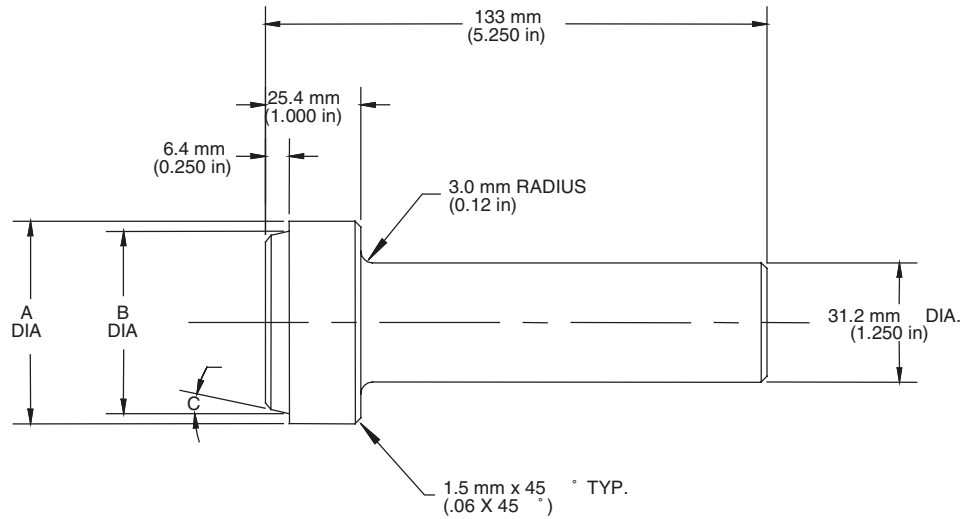

Pump Model	Part No	A	B	C
060 / 075 / 085	213-0-004193	2.120 in (53.8 mm)	1.918 in (48.7 mm)	12°
100	213-0-004205	2.562 in (65.1 mm)	2.335 in (59.3 mm)	15°
140	213-0-004198	2.80 in (71.1 mm)	2.562 in (65.1 mm)	15°

**Rotation Change Procedure**

- A. The B-mod C, L, or AM compensator is the same for both clockwise and counterclockwise rotation. The compensator position remains unchanged.
  - B. The port block is bi-rotational, so a new port block is not needed unless the existing port block is damaged during the rotation change. Therefore, the inlet and outlet port locations remain the same.
  - C. For the 45cc and larger pumps, the bias guide (#11) and control guide (#14) are located into the port block (#3), so they may be difficult to remove without damaging the guides or port block, so you may want to have extra guides or port block on hand.
1. Follow the disassembly instructions to the point at which the port plate (#9) can be accessed. The port plate is rotation dependent and will need to be changed. See part number tables and select the correct port plate. Use Figure 7 to verify that you have the correct rotation port plate. For the 18, 28, & 45cc units that are side ported with no thru drive, make sure you select the appropriate ripple chamber port plate because those units will have a ripple chamber in the port block as designated by the "R" in the model code description.
  2. Next, the port block control flow set screw (#6) needs to be swapped to the other passage way as shown in Figure 11. Remove the two boss plugs (#5) and remove the set screw and install in the other passage. Secure the set screw with Locktite 243 or equal and torque to 25 in-lbs. Then re-install the two plugs and torque them to 6 ft-lbs.

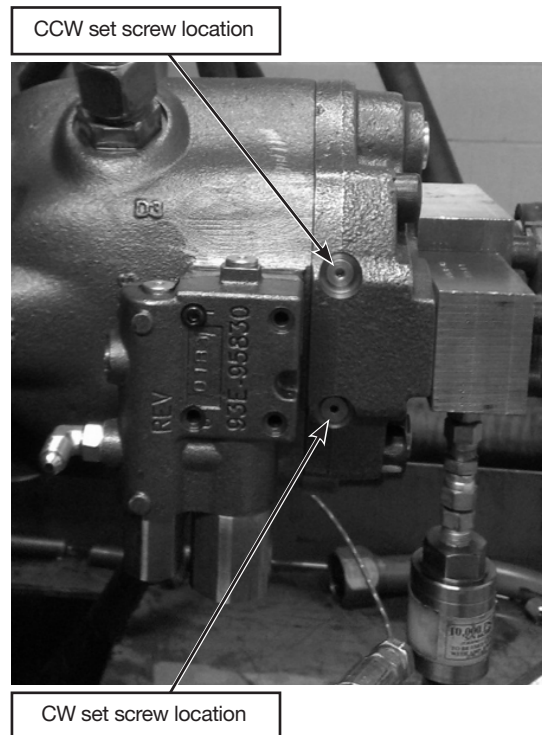
**Figure 11 – Port Block Control Flow Plug Location**

3. For 18, 28, 45cc units with ripple chambers, the rippler chamber set screw (#16) will need to be relocated to the opposite side as show in Figure 6 in the 18, 28, & 45cc assembly procedures. There will only be ripple chambers on side ported units that do not have a thru drive. Torque the ripple chamber set screw per the torque values in the torque table on page 6 or 7.

Rotation Change Procedure  
(Continued)

4. Next, the housing control flow set screw (#34) will need to be relocated to the other control flow passage as shown in Figure 12. Torque the set screw to 70 in-lbs.

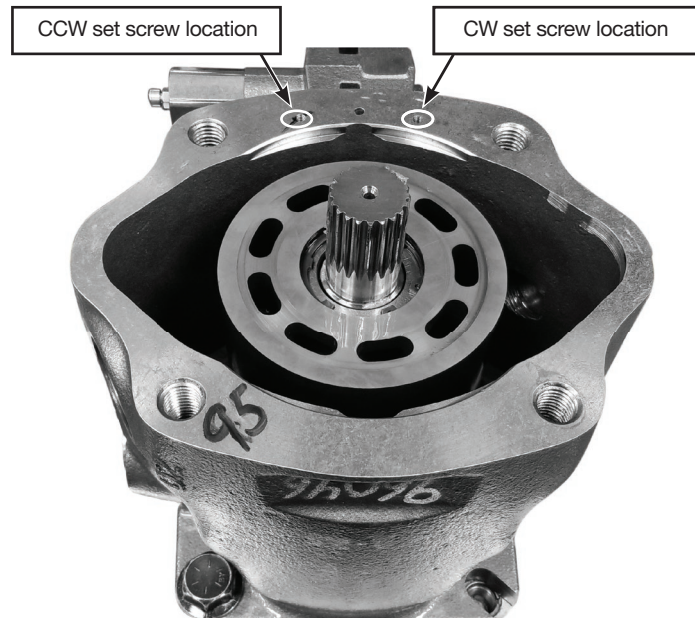

Figure 12 – Housing Control Flow Plug Location

5. For the 18 & 28cc pump, the control guide (#14) and bias guide (#11) are the same, so only the locations of the control piston (#15) and bias piston (#12) and spring (#13) need to be swapped.
6. For the 45cc units and larger, the bias guide (#11) and control guide (#14) are different, so remove the guides, control and bias pistons, and bias spring and swap their locations by following Steps 14-15 of the 60-140cc assembly procedures.
 

**NOTE:** The guides are located into the port block, so it may be difficult to remove them without damaging the port block or the guides themselves.
7. Now the pump can be reassembled per the Assembly Procedures section.
8. Test the pump per the Test Procedure section.

## Pump Test Procedure

Test criteria based on hydraulic oil ISO 32 per Parker HF-0 fluid specifications.

Operating speed: Do not exceed catalog ratings.

Maximum Case pressure: 2 bar (29 psi) absolute or 0.5 bar (7.5 psi) above inlet pressure.

Minimum inlet pressure: 0.8 bar (11.6 psi) absolute.

Oil temperatures: 120 F +/- 10 F (50 C +/- 5C).

**NOTE:** Ensure that hydraulic system does not overheat during this test procedure.

1. Mount pump on test fixture. Ensure that shaft alignment is within tolerance.
2. Fill pump case with clean oil. Connect uppermost case drain port to reservoir with no restrictions in between. Insure other case drain ports are properly plugged and torqued.
3. Connect inlet and outlet lines. Insure that lines are filled with oil. Refer to the hydraulic schematic test circuit diagrams. For pumps with “L” controls, connect a suitable pilot line from the “X” port on the pump control to the outlet pressure line downstream of the non-compensating flow valve (#4), and install a pressure gauge (#5) in the circuit that will read the pressure in that pilot line as shown in Circuit #1. For pumps with “AM” controls, connect a suitable pilot line from the “X” port on the control to a remote pressure relief valve (#14), and install a pressure gauge (#13) in that line as shown in Circuit #2.

**CAUTION:** Make sure a main system safety relief (#7) is installed in the system between the pump outlet and flow control valve (#4).

4. Confirm direction of rotation for the pump and drive is correct.
5. Reduce the main compensator (Pmax) setting to minimum by turning the Pmax adjustment screw counter-clockwise until the spring force is not felt. For pumps with the “L” or “AM” controls, turn the differential adjustment clockwise until it bottoms out and lock it into position.
6. Set the maximum volume stop (if applicable) to full displacement. If there is a minimum volume stop back that adjustment all the way out so that the pump can fully compensate.
7. Start the prime mover and if possible, gradually increase pump speed to 1800 rpm +/- 30 rpm with no load (no pressure on the system load relief valve #6).
8. While under no load, screw in the Pmax adjusting screw until it bottoms out.
9. Break in the pump at the time and pressures listed on the next page. Adjust the load-relief valve to the pressure listed for the times indicated. After break-in, loosen the Pmax adjustment screw lock nut and reduce the Pmax setting to the desired setting by turning the Pmax adjustment screw counter-clockwise until the pump pressure gauge reads the desired setting, and then tighten the lock nut. Next, adjust the system load relief valve to below the Pmax setting to cause the pump to come on stroke and then back above the Pmax setting to cause the pum to compensate. Repeat this at least three times to verify the pump compensates on and off stroke properly.
10. Use steps 10-12 for load sense pumps (“L” control option). Adjust the flow control valve and load relief valve such that the pump is compensated and the load pressure gauges read at least 300-500 psi.
11. Turn the differential screw counter-clockwise until the pump compensates and the difference between the load pressure gauge and pump outlet pressure equals the desired differential setting. Tighten the differential screw lock nut to lock the differential setting in place. The standard factory differential setting is 20 bar (290 psi). The minimum allowable setting is 10 bar (145 psi).

**Test Procedure**

**Pump Test Procedure  
(Continued)**

**Test Circuit**

1. Test pump
2. Test stand prime mover
3. Pump pressure gauge
4. Non-compensating flow control
5. Load pressure gauge
6. Load relief valve
7. Safety bypass relief valve
8. Main flow meter
9. Case drain pressure gauge
10. Case drain flow meter
11. Filter assembly with bypass
12. Cooler assembly with bypass
13. Remote port gauge
14. Reservoir

**NOTE:** Items 4 and 5 are required for load sense pump test. Remote relief valve and remote pressure gauge not shown for testing "AM" control option.

12. To determine the pump stand-by pressure, reduce the load relief setting to zero and confirm there is no pressure in the load sense line. The pump outlet pressure will be the stand-by pressure.
13. Use steps 13-15 for remote compensator pumps ("AM" control option). Close the load relief valve to deadhead the pump and adjust the remote relief valve so that the remote port gauge reads at least 300-500psi, and the difference between the remote and outlet port gauges is greater than the desired differential pressure setting.
14. Turn the differential screw counter-clockwise so that the difference between the remote port pressure and the pump outlet pressure equals the desired differential pressure. Tighten the differential screw lock nut to lock the differential setting in place. The standard factory differential setting is 20 bar (290 psi). The minimum allowable setting is 10 bar (145 psi).
15. To determine the pump stand-by pressure, reduce the remote relief setting to zero and confirm there is little to no pressure in the remote line. There may be a little pressure depending on the minimum pressure drop across the remote relief valve. The pump outlet pressure will be the stand-by pressure.

**NOTE:** For low Pmax settings (around 1000 psi or less), the differential pressure for the "L" and "AM" controls may not be adjustable. In this case, raise the Pmax setting to at least 1500 psi and repeat the pressure differential adjustment steps.

Time	60 seconds	60 seconds	60 seconds
Pressure	62-69 bar 900-1000 psi	200-207 bar 2900-3000 psi	269-276 bar 3900-4000 psi

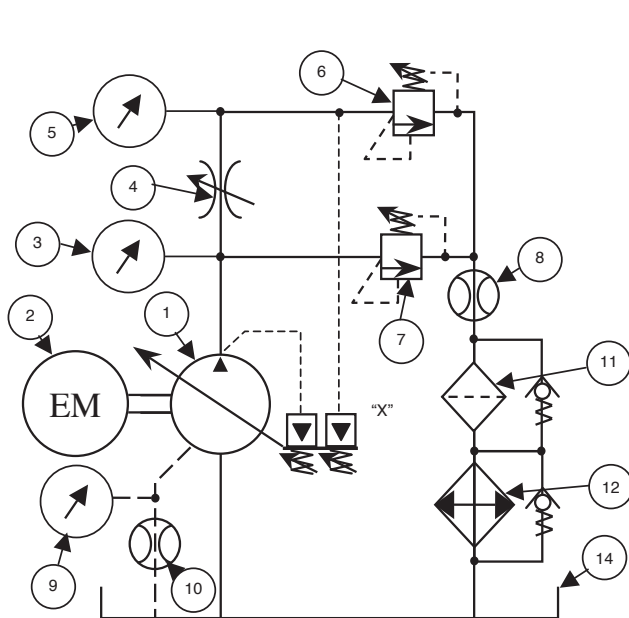

Circuit 1 - Load Sense Test Circuit Diagram

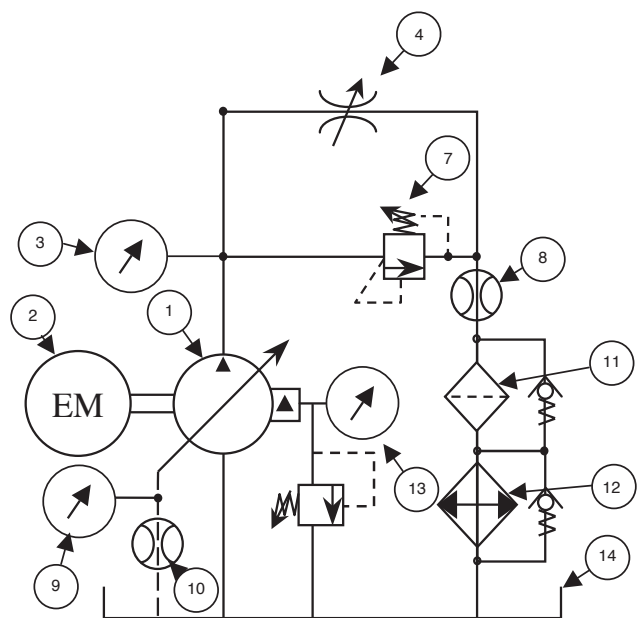

Circuit 2 - Remote Compensator Test Circuit Diagram

P1/PD Performance Test Pass/Fail Specifications								
Condition	018	028	045	060	075	085	100	140
Test Speed (rpm)	1800 (For All)							
Minimum outlet flow (L/min) at minimum pressure (500 psi)	30.7	46.9	77.2	102	129	148	170	239
Maximum case leakage (L/min) when compensated at 280 bar	5.7	7.6	11	13	15	16	20	23
Maximum input torque (Nm) when compensated at 280 bar	40	40	48	39	58	62	68	91
Minimum outlet flow (L/min) at 260 bar with compensator setting at 280 bar	28.4	44.7	72.7	100	123	143	166	233
Allowable load sense flow (L/min) variation from 50 to 260 bar	21.2	30.2	45.5	77	105	105	101	101

**Startup Procedure for  
New Installations**

- Read and understand the installation and start-up manual HY28-2709-02/P1/EN.
- Identify components and their function.
- Visually inspect components and lines for possible damage.
- Ensure that all necessary ports are properly connected.
- Check reservoir for cleanliness. Drain and clean as required.
- Check fluid level and fill as required with filtered fluid to a minimum ISO cleanliness level of 20/18/14.
- Fill pump case with clean oil prior to starting.
- If pump is mounted vertically with the shaft up, bleed the air out the D1 drain port located near the mounting flange.
- Check alignment of drive.
- Check oil cooler and activate it, if included in circuit. Check fluid temperature.
- Reduce pressure settings of compensator and relief valve. Make sure accurate pressure readings can be made at appropriate places.
- If solenoids in system, check for actuation.
- Jog the pump drive. Check for proper shaft rotation. Make sure pump fills properly.
- Start the pump drive.
- Bleed system of air. Recheck fluid level.
- Cycle unloaded machine at low pressure and observe actuation (at low speed, if possible).
- Increase pressure settings gradually in steps. Check for leaks in all lines especially in pump and motor inlet lines.
- Make correct pressure adjustments.
- Gradually increase speed. Be alert for trouble as indicated by changes in sounds, system shocks, and air in fluid.
- Equipment is operational.



Component problems and circuit problems are often interrelated. An improper circuit may operate with apparent success but will cause failure of a particular component within it. The component failure can be the effect, not the cause of the problem. This general guide is offered to help in locating and eliminating the cause of problems by studying their effects.

Effect of Trouble	Possible Cause	Fault Which Needs Remedy
Noisy pump	Air in fluid	Leak in inlet line
		Low fluid level
		Turbulent fluid
		Return lines above fluid level
		Gas leak from accumulator
		Excessive pressure drop in the inlet line from a pressurized reservoir
		Inlet line strainer acting as air trap
	Cavitation in rotating group	Fluid too cold
		Fluid too viscous
		Fluid too heavy
		Shaft speed too high
		Inlet line too small
		Inlet strainer too small
		Inlet strainer too dirty
		Operating altitude too high
	Misaligned shaft	Inlet pressure too low
		Faulty installation
		Distortion in mounting
		Axial interference
		Faulty coupling
Mechanical fault in pump	Excessive overhung loads	
	Piston and shoe looseness or failure	
	Bearing failure	
	Incorrect port plate rotation	
	Eroded or worn parts in the displacement control	
Erosion on barrel ports and port plate	Air in fluid	See noisy pump above
	Cavitation	See noisy pump above
Pressure shocks	Cogging load	Mechanical considerations
	Worn relief valve	Needed repairs
	Worn compensator	Replace
	Slow response in check valves	Replace or relocate
	Excessive decompression energy rates	Improve decompression control
	Barrel blow-off	Rotating group worn, excessive case pressure
Compensator instability	Line capacitance (line volume, line stretch, accumulator effects)	Change line size or lengths
		Add or remove hose
		Add orifice in load sense line
		Increase load sense differential pressure
	Outlet port check valve	Relocate check valve further from outlet port

**Troubleshooting**

Effect of Trouble	Possible Cause	Fault Which Needs Remedy
High wear in pump	Excessive loads	Reduce pressure settings
		Reduce speeds
	Contaminant particles in fluid	Improper filter maintenance
		Filters too coarse
		Introduction of dirty fluid to system
		Reservoir openings
		Improper reservoir breather
		Improper line replacement
	Improper fluid	Fluid too thin or thick for operating temperature range
		Breakdown of fluid with time/temperature/heating effects
		Incorrect additives in new fluid
		Destruction of additive effectiveness with chemical aging
	Improper repair	Incorrect parts
		Incorrect procedures, dimensions, finishes
	Unwanted water in fluid	Condensation
Faulty breather/strainer		
Heat exchanger leakage		
Faulty clean-up practice		
Water in makeup fluid		
Heating of fluid	Excessive pump leakage	Recheck case drain flow and repair as required
		Fluid too thin
		Improper assembly, port timing
	Relief valve	Set too low (compared to load or to compensator)
		Instability caused by back pressure, worn parts
	Compensator	Set too high (compared to relief)
		Worn parts
	Pump too large for fluid needs	Select smaller pump displacement
	Heat exchanger	Water turned off or too little flow
		Water too hot
		Fan clogged or restricted
		Efficiency reduced by mud or scale deposits
		Intermittent hydraulic fluid flow
	Reservoir	Too little fluid
		Improper baffles
Insulating air blanket that prevents heat rejection		
Heat pickup from adjacent equipment		

**Conversions and Formulas**

**CONVERSION FACTORS**

**DEFINITION & UNIT**

Displacement	$\text{in}^3/\text{rev} \times 16.387 = \text{cm}^3/\text{rev}$	$\text{cm}^3/\text{rev} \times 0.06102 = \text{in}^3/\text{rev}$
Flow	$\text{gpm} \times 3.78 = \text{L}/\text{min}$	$\text{L}/\text{min} \times 0.2642 = \text{gpm}$
Power	$\text{hp} \times 0.7457 = \text{kW}$	$\text{kW} \times 1.341 = \text{hp}$
Torque	$\text{lb-ft} \times 1.3567 = \text{Nm}$	$\text{Nm} \times 0.7376 = \text{lb-ft}$
Pressure	$\text{lbs}/\text{in}^2 \text{ (psi)} \times 0.06895 = \text{bar}$ $\text{lbs}/\text{in}^2 \text{ (psi)} \times 6.895 = \text{kPa}$	$\text{bar} \times 14.50 = \text{lbs}/\text{in}^2 \text{ (psi)}$ $\text{kPa} \times 0.1450 = \text{lbs}/\text{in}^2 \text{ (psi)}$
Weight	$\text{lb} \times 0.4536 = \text{kg}$	$\text{kg} \times 2.205 = \text{lbs}$
Force	$\text{lb} \times 4.448 = \text{N}$	$\text{N} \times 0.2248 = \text{lbs}$
Volume	$\text{in}^3 \times 16.387 = \text{cm}^3$	$\text{cm}^3 \times 0.06102 = \text{in}^3$
Area	$\text{in}^2 \times 6.452 = \text{cm}^2$	$\text{cm}^2 \times 0.1550 = \text{in}^2$
Length	$\text{in} \times 25.4 = \text{mm}$	$\text{mm} \times 0.03937 = \text{in}$
Temperature	$\frac{\text{degree F}-32}{1.8} = \text{°C}$	$1.8 \times \text{C}+32 = \text{°F}$
Viscosity	$\text{cSt} \times 1.0 = \text{mm}^2/\text{sec}$ $\text{SSU} = \text{cSt} \times 4.25 + 14$	$\text{mm}^2/\text{sec} \times 1.0 = \text{cSt}$ $20 \text{ cSt} = 99 \text{ SSU}$

**FLUID POWER FORMULAS**

Pump input torque	lbs. in.	$\frac{\text{pressure(psi)} \times \text{displacement (in}^3/\text{rev)}}{2\pi \times \text{mech. eff.}}$
Pump input power	hp	$\frac{\text{rpm} \times (\text{in}^3/\text{rev}) \times (\text{psi})}{395934 \times \text{overall eff.}}$
Pump output flow	U.S. gpm	$\frac{\text{rpm} \times (\text{in}^3/\text{rev}) \times \text{volumetric eff.}}{231}$
Fluid motor speed	rpm	$\frac{231 \times \text{flow rate(U.S. gpm)} \times \text{volumetric eff.}}{\text{displacement (in}^3/\text{rev)}}$
Fluid motor torque	lbs. in.	$\frac{\text{pressure(psi)} \times \text{displacement (in}^3/\text{rev)} \times \text{mech. eff.}}{2\pi}$
Fluid motor power	hp	$\frac{\text{rpm} \times (\text{in}^3/\text{rev}) \times (\text{psi}) \times \text{overall eff.}}{395934}$
<b>(Metric)</b>		
Pump input torque	Nm	$\frac{\text{pressure(bar)} \times \text{displacement (cm}^3/\text{rev)}}{20\pi \times \text{mech. eff.}}$
Pump input power	kW	$\frac{\text{rpm} \times (\text{cm}^3/\text{rev}) \times (\text{bar})}{600000 \times \text{overall eff.}}$
Pump output flow	Lpm	$\frac{\text{rpm} \times (\text{cm}^3/\text{rev}) \times \text{volumetric eff.}}{1000}$
Fluid motor speed	rpm(min <sup>-1</sup> ) (tr/mn)	$\frac{1000 \times \text{flow rate (Lpm)} \times \text{volumetric eff.}}{\text{displacement (cm}^3/\text{rev)}}$
Fluid motor torque	Nm	$\frac{\text{pressure(bar)} \times \text{displacement (cm}^3/\text{rev)} \times \text{mech. eff.}}{20\pi}$
Fluid motor power	kW	$\frac{\text{rpm} \times (\text{cm}^3/\text{rev}) \times (\text{bar}) \times \text{overall eff.}}{600000}$



**Revision Changes****April 2024**

- Updated misc parts to current part number
- Added AN, ANT, & Unload parts kits
- Removed orifice from ANT control exploded view and schematic
- Added AG control part numbers

**December 2020**

- Added 45 & 60 LOT & AMT torque limiter
- Added AN, ANT, AE/AF, AG/AH controls
- Added P, S, T, U controls
- Updated miscellaneous part numbers

**July 2019**

- 085 pressure ratings correction
- Miscellaneous part number corrections
- AMT schematic correction
- Amended the differential setting test procedure

**Warning and Disclaimer**

The product information, specifications, and descriptions contained in this publication have been compiled for the use and convenience of our customers from information furnished by the manufacturer; and we can not, and do not, accept any responsibility for the accuracy or correctness of any description, calculation, specification, or information contained herein. No such description, calculation, specification, or information regarding the products being sold has been made part of the basis of the bargain, nor has same created or amounted to an express warranty that the products would conform thereto. We are selling the goods and merchandise illustrated and described on this publication on an "as is" basis, and disclaim any implied warranty, including any warranty of merchantability or warranty of fitness for any particular purpose whatsoever, with respect to the goods and merchandise sold. All manufacturer warranties shall be passed on to our customers, but we shall not be responsible for special, indirect, incidental, or consequential damages resulting from the use of any of the products or information contained or described on this publication. Further, we reserve the right to revise or otherwise make product improvements at any time without notification.

**WARNING - USER RESPONSIBILITY**

FAILURE OR IMPROPER SELECTION OR IMPROPER USE OF THE PRODUCTS DESCRIBED HEREIN OR RELATED ITEMS CAN CAUSE DEATH, PERSONAL INJURY AND PROPERTY DAMAGE.

This document and other information from Parker-Hannifin Corporation, its subsidiaries and authorized distributors provide product or system options for further investigation by users having technical expertise.

The user, through its own analysis and testing, is solely responsible for making the final selection of the system and components and assuring that all performance, endurance, maintenance, safety and warning requirements of the application are met. The user must analyze all aspects of the application, follow applicable industry standards, and follow the information concerning the product in the current product catalog and in any other materials provided from Parker or its subsidiaries or authorized distributors.

To the extent that Parker or its subsidiaries or authorized distributors provide component or system options based upon data or specifications provided by the user, the user is responsible for determining that such data and specifications are suitable and sufficient for all applications and reasonably foreseeable uses of the components or systems.

**OFFER OF SALE**

The items described in this document are hereby offered for sale by Parker-Hannifin Corporation, its subsidiaries or its authorized distributor. This offer and its acceptance are governed by the provisions stated in the detailed "Offer of Sale" elsewhere in this document.

Parker Hannifin Corporation  
**Hydraulic Pump and Power Systems Division**  
14249 Industrial Pkwy  
Marysville, OH 43040 USA  
phone 937 644 4435  
fax 937 642 3639  
[www.parker.com/hps](http://www.parker.com/hps)

