

Valve Block
P6/7/8P/V/X/S/L/R
Assembly Reference
S23-12742

Valve Block
P6/7/8D
Assembly Reference
S23-12771

Seal Kit
S23-00135-0
S23-00135-4
S23-00135-5

Repair Kit
S23-17563-0
S23-17563-4
S23-17563-5

Section View - F - Valve Block Assembly

Section F P6/7/8 Valve Blocks Assembly					
Balloon #	Pump Type	Seal Code	Item #	Description	Qty.
F1	P/V/X/S/L/R	**	033-91221-0	VALVE BLK	1
	D		033-91334-0	VALVE BLK OPEN LOOP	
F2	P/V/X/S/L/R	**	S13-40266-0	VALVE CHECK	2
F3	P/V/X/S/L/R	**	033-91249-0	ORIFICE (.0465 DIA.) PLUG	4
F4	P/V/X/S/L/R	1	691-00903-0	O RING	3
	P/V/X/S/L/R	4	674-00903-0		
	P/V/X/S/L/R	5	695-00903-0		
F5	P/V/X/S/L/R	**	033-70508-0	SEAT	1
F6	P/V/X/S/L/R	**	312-13160-0	SCREW, SOC HD	1
F7	P/V/X/S/L/R	**	335-13100-0	NUT, HEX JAM	1
F8	P/V/X/S/L/R	**	033-70545-0	GUIDE-HOUSING	1
F9	P/V/X/S/L/R	1	691-00910-0	O RING	1
	P/V/X/S/L/R	4	674-00910-0		
	P/V/X/S/L/R	5	695-00910-0		
F10	P/V/X/S/L/R	**	036-21767-0	PISTON SEAL	1
F11	P/V/X/S/L/R	1	671-00012-0	O RING	2
	P/V/X/S/L/R	4	674-00012-0		
	P/V/X/S/L/R	5	675-00012-0		
F12	P/V/X/S/L/R	**	032-91798-0	SPRING	1
F13	P/V/X/S/L/R	**	036-12288-0	CONE	1
F14	P/V/X/S/L/R	**	S13-43240-0	SERVO STRAINER	1
F19	P/V/X/S/L/R	1	691-00906-0	O RING	1
	P/V/X/S/L/R	4	674-00906-0		
	P/V/X/S/L/R	5	695-00906-0		
F20	P/V/X/S/L/R	**	488-35003-0	PLUG	1
F21	P/V/X/S/L/R	**	230-82226-0	PIN 1/8 X 4/8	1
	D		033-92868-0	PIN .156 X .61	
F22	P/V/X/S/L/R	1	691-00904-0	O RING	5
	P/V/X/S/L/R	4	674-00904-0		
	P/V/X/S/L/R	5	695-00904-0		
F23	P/V/X/S/L/R	**	488-35001-0	PLUG	5
F25	P/V/X/S/L/R	**	488-35049-0	PLUG	2
F27	P/V/X/S/L/R	**	033-70507-0	SEAT SEQ REL	2

Section View - F - Valve Block Assembly

Section F P6/7/8 Valve Blocks Assembly					
Balloon #	Pump Type	Seal Code	Item #	Description	Qty.
F28	P/V/X/S/L/R	**	033-70500-0	REPL. + SERVO SEAT	4
F29	P/V/X/S/L/R	**	033-91193-0	GASKET	1
F30	P/V/X/S/L/R	**	033-72378-0	POPPET, SEQ.	2
F31	P/V/X/S/L/R	**	033-72379-0	POPPET, DUAL + REPL	4
F32	P/V/X/S/L/R	**	033-22141-0	SPRING, REPL	1
	D		033-72693-0	SPRING, REPL	
F33	P/V/X/S/L/R	**	033-70512-0	SPRING, SEQ./SERVO	2
F34	P/V/X/S/L/R	**	033-70482-0	SPRING RETAINER	1
F35	P/V/X/S/L/R	**	033-71086-0	SPRING, DUAL RELIEF	3
F36	P/V/X/S/L/R	**	S23-12814-0	VALVE, REPLEN PILOT	1
F37	P/V/X/S/L/R	1	671-00050-0	O RING	1
	P/V/X/S/L/R	4	674-00050-0		
	P/V/X/S/L/R	5	675-00050-0		
F42	P/V/X/S/L/R	**	033-91422-0	RETAINER PLATE	1
F43	P/V/X/S/L/R	**	353-25078-0	SCREW, BUTTON HD	4
F45	P/V/X/S/L/R	**	327-25006-0	NUT, ACORN	1
F46	P/V/X/S/L/R	**	325-08120-0	PIN, ROLL 1/8 X 3/4 LG	2
F47	P/V/X/S/L/R	1	671-00013-0	O RING	2
	P/V/X/S/L/R	4	674-00013-0		
	P/V/X/S/L/R	5	675-00013-0		
F48	P/V/X/S/L/R	1	671-00014-0	O RING	2
	P/V/X/S/L/R	4	674-00014-0		
	P/V/X/S/L/R	5	675-00014-0		
F49	P/V/X/S/L/R	**	306-40169-0	SCREW HHC	8

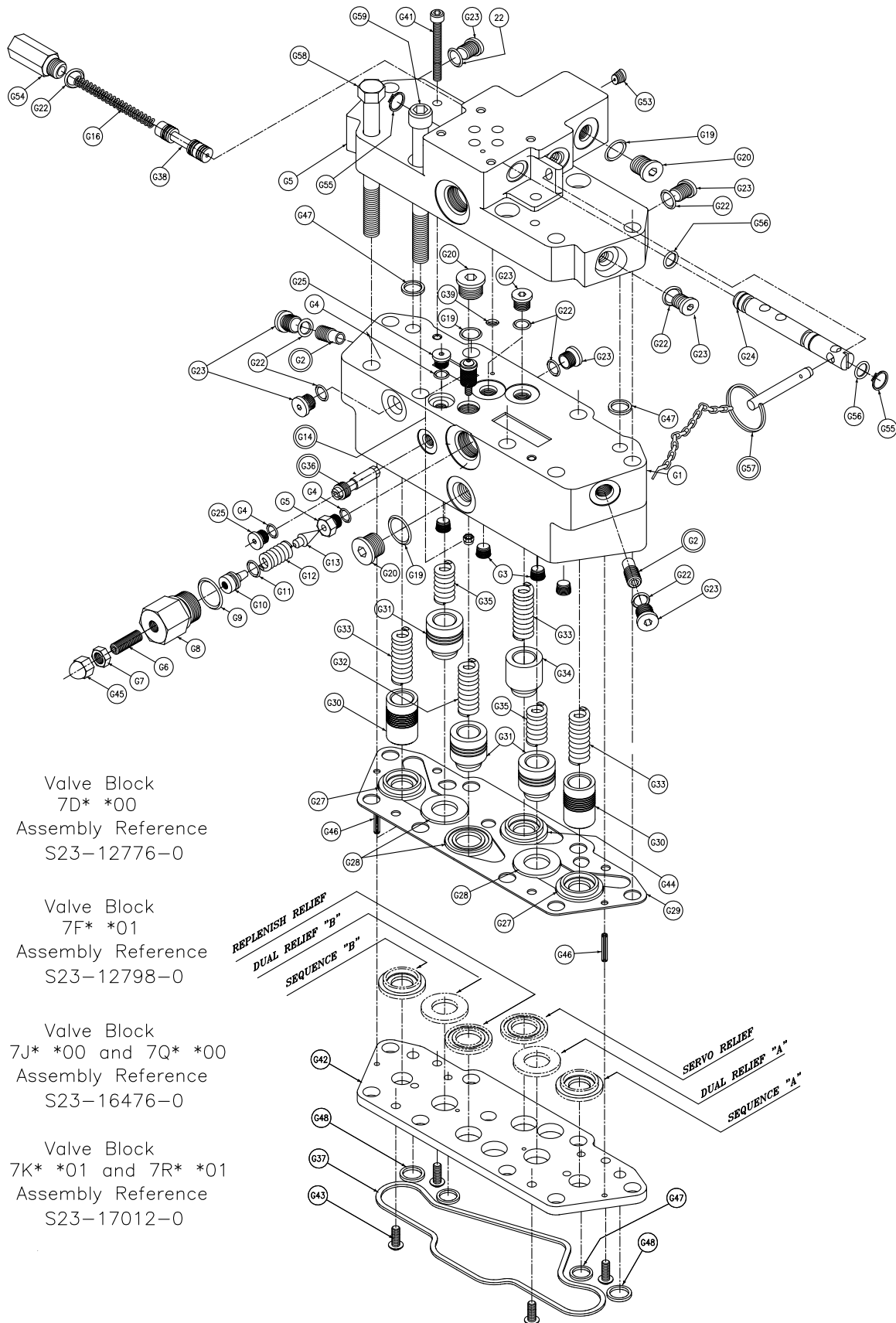

Valve Block
7D* *00
Assembly Reference
S23-12776-0

Valve Block
7F* *01
Assembly Reference
S23-12798-0

Valve Block
7J* *00 and 7Q* *00
Assembly Reference
S23-16476-0

Valve Block
7K* *01 and 7R* *01
Assembly Reference
S23-17012-0

REPLENISH RELIEF
DUAL RELIEF "B"
SEQUENCE "B"

SERVO RELIEF
DUAL RELIEF "A"
SEQUENCE "A"

Section View - G - Valve Block Assembly for 700 Control

Section G P6/7/8 Valve Blocks Assemblies for 700 Control					
Balloon #	Primary 700 Control	Seal Code	Item #	Description	Qty
G1	ALL	**	033-91335-0	VALVE BLK	1
G2	ALL	**	S13-40266-0	VALVE CHECK	2
G3	ALL	**	033-91249-0	ORIFICE (.0465 DIA.) PLUG	4
G4	ALL	1	691-00903-0	O RING	3
	ALL	4	674-00903-0		
	ALL	5	695-00903-0		
G5	ALL	**	033-70508-0	SEAT	1
G6	ALL	**	312-13160-0	SCREW, SOC HD	1
G7	ALL	**	335-13100-0	NUT, HEX JAM	1
G8	ALL	**	033-70545-0	GUIDE-HOUSING	1
G9	ALL	1	691-00910-0	O RING	1
	ALL	4	674-00910-0		
	ALL	5	695-00910-0		
G10	ALL	**	036-21767-0	PISTON SEAL	1
G11	ALL	1	671-00012-0	O RING	2
	ALL	4	674-00012-0		
	ALL	5	675-00012-0		
G12	ALL	**	032-91798-0	SPRING	1
G13	ALL	**	036-12288-0	CONE	1
G14	ALL	**	S13-43240-0	SERVO STRAINER	1
G15	7F* **01	**	033-54446-0	MANIFOLD FOR SHUTOFF	1
	7D* **00	**	033-54389-0	MANIFOLD LESS SHUTOFF	
	7K* **01, 7R* **01	**	033-93376-0	MANIFOLD FOR SHUTOFF	
	7J* **00, 7Q* **00	**	033-92887-0	MANIFOLD LESS SHUTOFF	
G16	ALL	**	225-92083-0	SPRING	1
G19	ALL	1	691-00906-0	O RING	3
	ALL	4	674-00906-0		
	ALL	5	695-00906-0		
G20	ALL	**	488-35041-0	PLUG	3
G22	ALL	1	691-00904-0	O RING	11
	ALL	4	674-00904-0		
	ALL	5	695-00904-0		
G23	ALL	**	488-35001-0	PLUG	10
G24	ALL	**	033-93866-0	SERVO SPOOL	1
G25	ALL	**	488-35049-0	PLUG	2
G27	ALL	**	033-70507-0	SEAT SEQ REL	2

Section View - G - Valve Block Assembly for 700 Control

Section G P6/7/8 Valve Blocks Assemblies for 700 Control					
Balloon #	Primary 700 Control	Seal Code	Item #	Description	Qty
G28	ALL	**	033-70500-0	REPL. + SERVO SEAT	3
G29	ALL	**	033-91193-0	GASKET	1
G30	ALL	**	033-72378-0	POPPET, SEQ.	2
G31	ALL	**	033-72379-0	POPPET, DUAL + REPL	3
G32	ALL	**	033-22141-0	SPRING, REPL	1
G33	ALL	**	033-70512-0	SPRING, SEQ./SERVO	3
G34	ALL	**	033-54398-0	POPPET SERVO	1
G35	ALL	**	033-71086-0	SPRING, DUAL RELIEF	2
G36	ALL	**	S23-12814-0	VALVE, REPLEN PILOT	1
G37	ALL	1	671-00050-0	O RING	1
	ALL	4	674-00050-0		
	ALL	5	675-00050-0		
G38	ALL	**	033-54392-0	SPOOL	1
G39	ALL	1	671-00008-0	O RING	2
	ALL	4	674-00008-0		
	ALL	5	675-00008-0		
G41	ALL	**	358-10180-0	SCREW SHC	2
G42	ALL	**	033-91422-0	RETAINER PLATE	1
G43	ALL	**	353-25078-0	SCREW, BUTTON HD	4
G44	ALL	**	033-54399-0	SERVO SEAT	1
G45	ALL	**	327-25006-0	NUT, ACORN	1
G46	ALL	**	325-08120-0	PIN, ROLL 1/8 X 3/4 LG	2
G47	ALL	1	671-00013-0	O RING	2
	ALL	4	674-00013-0		
	ALL	5	675-00013-0		
G48	ALL	1	671-00014-0	O RING	2
	ALL	4	674-00014-0		
	ALL	5	675-00014-0		
G50	ALL	**	449-00013-0	PLUG SHIPPING	1
G53	ALL	**	033-25528-0	ORIFICE	1
G54	ALL	**	035-54400-0	PLUG	1
G55	7F* *01, 7K* *01, 7R* *01	**	356-31043-0	RING RETAINING	2
G56	7F* *01, 7K* *01, 7R* *01	1	671-00011-0	O RING	2
		4	674-00011-0		
		5	675-00011-0		
G57	7F* *01, 7K* *01, 7R* *01	**	S23-02208-0	PIN	1

Section View - H - Motor Shuttle and Reverse Compensator Assembly

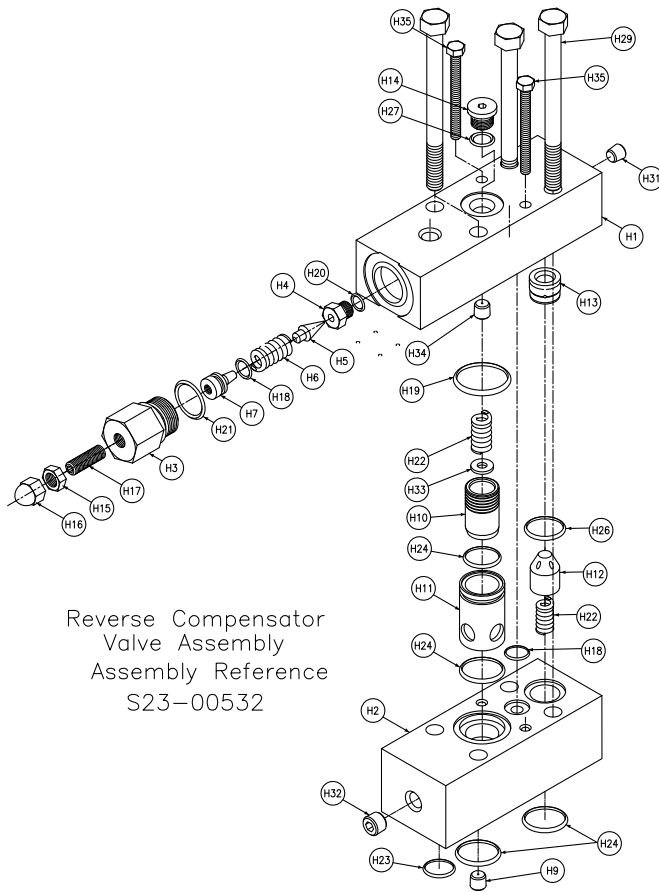

Reverse Compensator
Valve Assembly
Assembly Reference
S23-00532

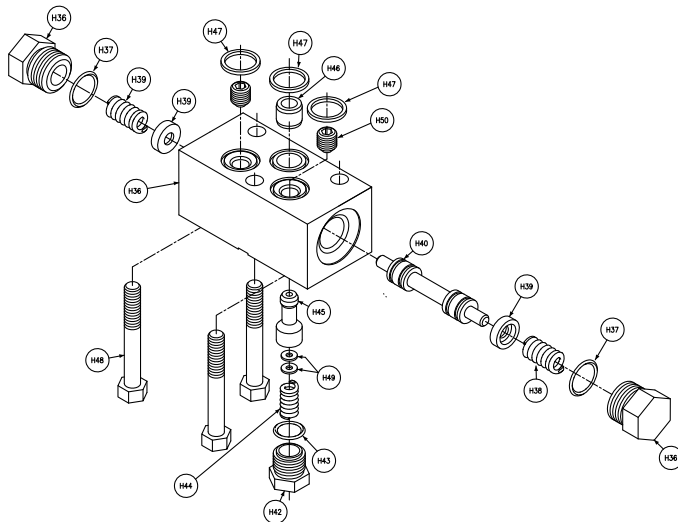

Shuttle Valve
Assembly Reference
S13-48776

Shuttle Valve Less H50
Assembly Reference
S13-48273

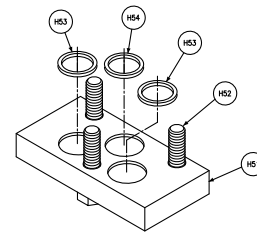

Cover Less Shuttle
Assembly Reference
S23-00181

Section View - H - Motor Shuttle and Reverse Compensator Assembly

Section H M6/7/8 H/V Shuttle & Reverse Compensator Assemblies					
Balloon #	Motor Type	Seal Code	Item #	Description	Qty
H1	H/V	**	033-53832-0	COVER	1
H2	H/V	**	033-53833-0	BODY REVERSE COMPENSATOR	1
H3	H/V	**	033-70545-0	GUIDE-HOUSING	1
H4	H/V	**	033-70508-0	SEAT	1
H5	H/V	**	036-12288-0	CONE	1
H6	H/V	**	032-91798-0	SPRING COMP	1
H7	H/V	**	036-21767-0	PISTON SEAL	1
H9	H/V	**	035-43275-0	ORIFICE #51(.067) 1/16 PT	1
H10	H/V	**	036-38466-0	PISTON	1
H11	H/V	**	036-38464-0	SLEEVE	1
H12	H/V	**	035-49407-0	POPPET	1
H13	H/V	**	035-49406-0	SEAT	1
H14	H/V	**	488-35001-0	PLUG	1
H15	H/V	**	335-13100-0	NUT, HEX JAM	1
H16	H/V	**	327-13005-0	NUT, ACORN	1
H17	H/V	**	312-13160-0	SCREW, SOCHD	1
H18	H/V	1	671-00012-0	O RING	2
	H/V	4	674-00012-0		
	H/V	5	675-00012-0		
H19	H/V	1	691-00022-0	O RING	1
	H/V	4	674-00022-0		
	H/V	5	675-00022-0		
H20	H/V	1	691-00903-0	O RING	1
	H/V	4	674-00903-0		
	H/V	5	695-00903-0		
H21	H/V	1	691-00910-0	O RING	1
	H/V	4	674-00910-0		
	H/V	5	695-00910-0		
H22	H/V	**	036-38449-0	SPRING	2
H23	H/V	1	691-10014-0	GASKET	1
	H/V	4	674-00014-0		
	H/V	5	695-10014-0		
H24	H/V	1	691-00018-0	O RING	4
	H/V	4	674-00018-0		
	H/V	5	695-00018-0		
H26	H/V	1	691-00017-0	O RING	1
	H/V	4	674-00017-0		
	H/V	5	675-00017-0		

Section H M6/7/8 H/V Shuttle & Reverse Compensator Assemblies					
Balloon #	Motor Type	Seal Code	Item #	Description	Qty
H27	H/V	1	691-00904-0	O RING	1
	H/V	4	674-00904-0		
	H/V	5	695-00904-0		
H29	H/V	*	306-40197-0	SCREW, HHC	4
H31	H/V	**	431-90104-0	1/16 PIPE PLUG	1
H32	H/V	**	431-90204-0	1/8 PIPE PLUG	1
H33	H/V	**	345-10008-0	WASHER	1
H34	H/V	**	800599	ORFICE .033/036 1/16 PIPE	1
H35	H/V	**	306-40167-0	SCREW, HHC	2
H36	H/L	**	033-93510-0	PLUG	2
H37	H/L	**	691-00908-0	O RING	2
	H/L	**	674-00908-0		
	H/L	**	695-00908-0		
H38	H/L	**	033-70515-0	SPRING	2
H39	H/L	**	033-70495-0	WASHER	2
H40	H/L	**	033-70529-0	SPOOL	1
H41	H/L	**	033-53117-0	SHUTTLE VALVE BODY	1
H42	H/L	**	033-72129-0	PLUG	1
H43	H/L	**	691-00906-0	O RING	1
	H/L	**	674-00906-0		
	H/L	**	695-00906-0		
H44	H/L	**	033-71923-0	SPRING	1
H45	H/L	**	033-71925-0	SPOOL	1
H46	H/L	**	033-53154-0	SEAT	1
H47	H/L	1	691-10016-0	GASKET	3
	H/L	4	674-10016-0		
	H/L	5	695-20016-0		
H48	H/L	**	306-40106-0	SCREW, HHC	3
H49	H/L	**	345-20004-0	WASHER BRASS	2
H50	H/L	**	033-53523-0	ORFICE .078	2
H51	V/R	**	033-71649-0	COVER PLATE	1
H52	V/R	**	306-40071-0	SCREW, HHC	3
H53	V/R	1	691-10014-0	GASKET	2
	V/R	4	674-00014-0		
	V/R	5	695-10014-0		
H54	V/R	1	691-10019-0	GASKET	1
	V/R	4	674-00019-0		
	V/R	5	695-10019-0		

The items described in this document and other documents and descriptions provided by Parker Hannifin Corporation, Hydraulics Group, and its authorized distributors ("Seller") are hereby offered for sale at prices to be established by Seller. This offer and its acceptance by any customer ("Buyer") shall be governed by all of the following Terms and Conditions. Buyer's order for any item described in its document, when communicated to Seller verbally, or in writing, shall constitute acceptance of this offer. All goods or work described will be

referred to as "Products".

1. Terms and Conditions. Seller's willingness to offer Products, or accept an order for Products, to or from Buyer is expressly conditioned on Buyer's assent to these Terms and Conditions and to the terms and conditions found on-line at www.parker.com/saleterms/. Seller objects to any contrary or additional term or condition of Buyer's order or any other document issued by Buyer.

2. Price Adjustments; Payments. Prices stated on the reverse side or preceding pages of this document are valid for 30 days. After 30 days, Seller may change prices to reflect any increase in its costs resulting from state, federal or local legislation, price increases from its suppliers, or any change in the rate, charge, or classification of any carrier. The prices stated on the reverse or preceding pages of this document do not include any sales, use, or other taxes unless so stated specifically. Unless otherwise specified by Seller, all prices are F.O.B. Seller's facility, and payment is due 30 days from the date of invoice. After 30 days, Buyer shall pay interest on any unpaid invoices at the rate of 1.5% per month or the maximum allowable rate under applicable law.

3. Delivery Dates; Title and Risk; Shipment. All delivery dates are approximate and Seller shall not be responsible for any damages resulting from any delay. Regardless of the manner of shipment, title to any products and risk of loss or damage shall pass to Buyer upon tender to the carrier at Seller's facility (i.e., when it's on the truck, it's yours). Unless otherwise stated, Seller may exercise its judgment in choosing the carrier and means of delivery. No deferment of shipment at Buyers' request beyond the respective dates indicated will be made except on terms that will indemnify, defend and hold Seller harmless against all loss and additional expense. Buyer shall be responsible for any additional shipping charges incurred by Seller due to Buyer's changes in shipping, product specifications or in accordance with Section 13, herein.

4. Warranty. Seller warrants that the Products sold hereunder shall be free from defects in material or workmanship for a period of eighteen months from the date of delivery to Buyer. The prices charged for Seller's products are based upon the exclusive limited warranty stated above, and upon the following disclaimer: **DISCLAIMER OF WARRANTY: THIS WARRANTY COMPRISES THE SOLE AND ENTIRE WARRANTY PERTAINING TO PRODUCTS PROVIDED HEREUNDER. SELLER DISCLAIMS ALL OTHER WARRANTIES, EXPRESS AND IMPLIED, INCLUDING MERCHANTABILITY AND FITNESS FOR A PARTICULAR PURPOSE.**

5. Claims; Commencement of Actions. Buyer shall promptly inspect all Products upon delivery. No claims for shortages will be allowed unless reported to the Seller within 10 days of delivery. No other claims against Seller will be allowed unless asserted in writing within 60 days after delivery or, in the case of an alleged breach of warranty, within 30 days after the date within the warranty period on which the defect is or should have been discovered by Buyer. Any action based upon breach of this agreement or upon any other claim arising out of this sale (other than an action by Seller for any amount due to Seller from Buyer) must be commenced within thirteen months from the date of tender of delivery by Seller or, for a cause of action based upon an alleged breach of warranty, within thirteen months from the date within the warranty period on which the defect is or should have been discovered by Buyer.

6. LIMITATION OF LIABILITY. UPON NOTIFICATION, SELLER WILL, AT ITS OPTION, REPAIR OR REPLACE A DEFECTIVE PRODUCT, OR REFUND THE PURCHASE PRICE. IN NO EVENT SHALL SELLER BE LIABLE TO BUYER FOR ANY SPECIAL, INDIRECT, INCIDENTAL OR CONSEQUENTIAL DAMAGES ARISING OUT OF, OR AS THE RESULT OF, THE SALE, DELIVERY, NON-DELIVERY, SERVICING, USE OR LOSS OF USE OF THE PRODUCTS OR ANY PART THEREOF, OR FOR ANY CHARGES OR EXPENSES OF ANY NATURE INCURRED WITHOUT SELLER'S WRITTEN CONSENT, EVEN IF SELLER HAS BEEN NEGLIGENT, WHETHER IN CONTRACT, TORT OR OTHER LEGAL THEORY. IN NO EVENT SHALL SELLER'S LIABILITY UNDER ANY CLAIM MADE BY BUYER EXCEED THE PURCHASE PRICE OF THE PRODUCTS.

7. Contingencies. Seller shall not be liable for any default or delay in performance if caused by circumstances beyond the reasonable control of Seller.

8. User Responsibility. The user, through its own analysis and testing, is solely responsible for making the final selection of the system and Product and assuring that all performance, endurance, maintenance, safety and warning requirements of the application are met. The user must analyze all aspects of the application and follow applicable industry standards and Product information. If Seller provides Product or system options, the user is responsible for determining that such data and specifications are suitable and sufficient for all applications and reasonably foreseeable uses of the Products or systems.

9. Loss to Buyer's Property. Any designs, tools, patterns, materials, drawings, confidential information or equipment furnished by Buyer or any other items which become Buyer's property, may be considered obsolete and may be destroyed by Seller after two consecutive years have elapsed without Buyer placing an order for the items which are manufactured using such property. Seller shall not be responsible for any loss or damage to such property while it is in Seller's possession or control.

10. Special Tooling. A tooling charge may be imposed for any special tooling, including without limitation, dies, fixtures, molds and patterns, acquired to manufacture Products. Such special tooling shall be and remain Seller's property notwithstanding payment of any charges by Buyer. In no event will Buyer acquire any interest in apparatus belonging to Seller which is utilized in the manufacture of the Products, even if such apparatus has been specially converted or adapted for such manufacture and notwithstanding any charges paid by Buyer. Unless otherwise agreed, Seller shall have the right to alter, discard or

otherwise dispose of any special tooling or other property in its sole discretion at any time.

11. Buyer's Obligation; Rights of Seller. To secure payment of all sums due or otherwise, Seller shall retain a security interest in the goods delivered and this agreement shall be deemed a Security Agreement under the Uniform Commercial Code. Buyer authorizes Seller as its attorney to execute and file on Buyer's behalf all documents Seller deems necessary to perfect its security interest. Seller shall have a security interest in, and lien upon, any property of Buyer in Seller's possession as security for the payment of any amounts owed to Seller by Buyer.

12. Improper Use and Indemnity. Buyer shall indemnify, defend, and hold Seller harmless from any claim, liability, damages, lawsuits, and costs (including attorney fees), whether for personal injury, property damage, patent, trademark or copyright infringement or any other claim, brought by or incurred by Buyer, Buyer's employees, or any other person, arising out of: (a) improper selection, improper application or other misuse of Products purchased by Buyer from Seller; (b) any act or omission, negligent or otherwise, of Buyer; (c) Seller's use of patterns, plans, drawings, or specifications furnished by Buyer to manufacture Product; or (d) Buyer's failure to comply with these terms and conditions. Seller shall not indemnify Buyer under any circumstance except as otherwise provided.

13. Cancellations and Changes. Orders shall not be subject to cancellation or change by Buyer for any reason, except with Seller's written consent and upon terms that will indemnify, defend and hold Seller harmless against all direct, incidental and consequential loss or damage. Seller may change product features, specifications, designs and availability with notice to Buyer.

14. Limitation on Assignment. Buyer may not assign its rights or obligations under this agreement without the prior written consent of Seller.

15. Entire Agreement. This agreement contains the entire agreement between the Buyer and Seller and constitutes the final, complete and exclusive expression of the terms of the agreement. All prior or contemporaneous written or oral agreements or negotiations with respect to the subject matter are herein merged.

16. Waiver and Severability. Failure to enforce any provision of this agreement will not waive that provision nor will any such failure prejudice Seller's right to enforce that provision in the future. Invalidation of any provision of this agreement by legislation or other rule of law shall not invalidate any other provision herein. The remaining provisions of this agreement will remain in full force and effect.

17. Termination. This agreement may be terminated by Seller for any reason and at any time by giving Buyer thirty (30) days written notice of termination. In addition, Seller may by written notice immediately terminate this agreement for the following: (a) Buyer commits a breach of any provision of this agreement (b) the appointment of a trustee, receiver or custodian for all or any part of Buyer's property (c) the filing of a petition for relief in bankruptcy of the other Party on its own behalf, or by a third party (d) an assignment for the benefit of creditors, or (e) the dissolution or liquidation of the Buyer.

18. Governing Law. This agreement and the sale and delivery of all Products hereunder shall be deemed to have taken place in and shall be governed and construed in accordance with the laws of the State of Ohio, as applicable to contracts executed and wholly performed therein and without regard to conflicts of laws principles. Buyer irrevocably agrees and consents to the exclusive jurisdiction and venue of the courts of Cuyahoga County, Ohio with respect to any dispute, controversy or claim arising out of or relating to this agreement. Disputes between the parties shall not be settled by arbitration unless, after a dispute has arisen, both parties expressly agree in writing to arbitrate the dispute.

19. Indemnity for Infringement of Intellectual Property Rights. Seller shall have no liability for infringement of any patents, trademarks, copyrights, trade dress, trade secrets or similar rights except as provided in this Section. Seller will defend and indemnify Buyer against allegations of infringement of U.S. patents, U.S. trademarks, copyrights, trade dress and trade secrets ("Intellectual Property Rights"). Seller will defend at its expense and will pay the cost of any settlement or damages awarded in an action brought against Buyer based on an allegation that a Product sold pursuant to this Agreement infringes the Intellectual Property Rights of a third party. Seller's obligation to defend and indemnify Buyer is contingent on Buyer notifying Seller within ten (10) days after Buyer becomes aware of such allegations of infringement, and Seller having sole control over the defense of any allegations or actions including all negotiations for settlement or compromise. If a Product is subject to a claim that it infringes the Intellectual Property Rights of a third party, Seller may, at its sole expense and option, procure for Buyer the right to continue using the Product, replace or modify the Product so as to make it noninfringing, or offer to accept return of the Product and return the purchase price less a reasonable allowance for depreciation. Notwithstanding the foregoing, Seller shall have no liability for claims of infringement based on information provided by Buyer, or directed to Products delivered hereunder for which the designs are specified in whole or part by Buyer, or infringements resulting from the modification, combination or use in a system of any Product sold hereunder. The foregoing provisions of this Section shall constitute Seller's sole and exclusive liability and Buyer's sole and exclusive remedy for infringement of Intellectual Property Rights.

20. Taxes. Unless otherwise indicated, all prices and charges are exclusive of excise, sales, use, property, occupational or like taxes which may be imposed by any taxing authority upon the manufacture, sale or delivery of Products.

21. Equal Opportunity Clause. For the performance of government contracts and where dollar value of the Products exceed \$10,000, the equal employment opportunity clauses in Executive Order 11246, VEVRAA, and 41 C.F.R. §§ 60-1.4(a), 60-741.5(a), and 60-250.4, are hereby incorporated.



May 2023

First edition: Variable Displacement Pump options for P/M6-7-8 catalog
HY28-2667-03/GC/US



WARNING

The products described in this catalog can expose you to chemicals, including Lead, which is known to the State of California to cause cancer and birth defects or other reproductive harm. For more information go to www.p65warnings.ca.gov.

Parker Hannifin Corporation
Hydraulic Pump and Power Systems Division
14249 Industrial Pkwy
Marysville, OH 43040 USA
phone 937 644 4532
fax 937 642 3639
www.parker.com/hps

